

# Section 12

- Belt Drives, BDL ..... 4-15
- Belts ..... 2-4
- Belt & Chain Guards ..... 50-53
- Chain .....46-47
- Chain Adjusters ..... 54
- Compensating Sprockets/Kits..... 45-49
- Derby & Inspect. Covers ...24-28, 36-39
- Primary**
  - Inner, Big Twin .....29-35
  - Outer, Big Twin ..... 21-24
  - Sportster ..... 36-40
- Pulleys/Covers .....15-20
- Sprockets ..... 41-45

# Replacement Belts

**Note:**  
The replacement belts offered for sale on this page have no warranty whatsoever.

## 8mm Rubber Primary Belts

Bullseye belts are about .020 longer.

PCP	Size	Teeth	F/R Pulley
42059	8mm x 42mm	130	48-68 Kevlar
42060	8mm 1-3/4"	132	48-72
42062	8mm x 42mm	138	45-68 Kevlar (1-5/8")
42064	8mm x 38mm	138	45-68 Kevlar
42065	8mm 1-3/4"	141	47-72
42066	8mm 1-5/8"	132	48-72
42067	8mm 1-5/8"	141	47-72
42089	8mm 3"	132	44-76 Bullseye
42068	8mm 3"	141	47-72
42069	8mm 3"	132	48-72
3204	8.07mm 1-1/2"	132	41-61
42090	8mm 1-1/2"	132	41-61 Kevlar
3206	8mm 1-1/2"	132	41-61, 39-62, Bullseye
3207	8mm 1-1/2"	144	47-76
42092	8mm 1-1/2"	144	As above, Kevlar
3208	8mm 2"	144	47-76 2T & 2S
3209	8mm 3"	144	47-76 3T & 3S
42086	8mm 3"	140	
42087	8mm 4"	140	
3202	8mm 1-1/2"	117	45-76 Sporster
3203	8mm 1-3/4"	117	45-76 Sportster
42056	8.07mm 1-1/2"	132	Kevlar
42085	8.07mm 1-3/4"	132	Kevlar
42057	8.07mm 3"	132	Kevlar



42052

## Panther Rubber Racing Belts

42052	8mm 3"	144	Panther
42053	8mm 3"	140	Panther
42054	8mm 3"	130	Panther
42055	8mm 3"	120	Panther

**41mm = 1-1/2" Wide**

**42mm = 1-5/8" Wide**

.....  
 : **Note:** All belts by Primo, Falcon or BDL are manufactured  
 : by Gates Rubber, Goodyear or Dayco Panther.  
 : Belts **do not** carry any warranty, of any kind, whether sold  
 : separately or in a complete kit.  
 : .....

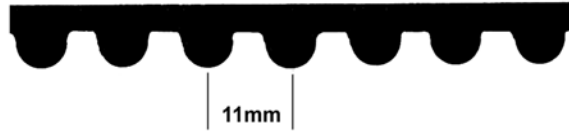

## 11mm Rubber Primary Belts

PCP	Size	Teeth	F/R Pulley
3199	11mm 1-1/2"	99	31-47 (4 speed)
42083	11mm 1-1/2"	92	31-47 (5 speed)
3220	11mm 1-1/2"	96	29-44, 28-44

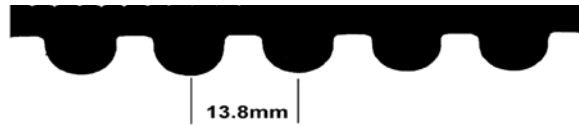

## 13.8mm Polychain Primary Belts

PCP	Size	Teeth	F/R Pulley
42081	13.8mm 1-1/8"	78	Sturgis (stock)
3213	13.8mm 1-1/2"	78	Karata
42084	13.8mm 1-3/4"	78	Karata

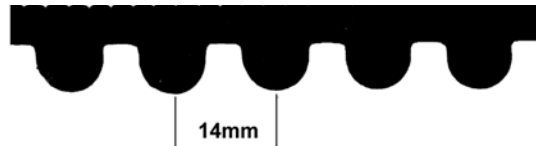

## 14mm Primary Belts

PCP	Size	Teeth	F/R Pulley
3214	14mm 1-1/2"	69	Polychain
42082	14mm 1-3/4"	69	As above
3216	14mm 1-1/2"	78	24-37, 24-38 (4 speed)
3217	14mm 1-1/2"	72	24 -37 (5-spd) BT 80-84

## Emergency Belt Kit

Kit includes a spliced belt, hardware, allen wrench and detailed instructions. 1-1/8" wide.

PCP	Teeth
29201	130T (40171-97)
29202	132T (40109-86)
29203	136T (40100-85)

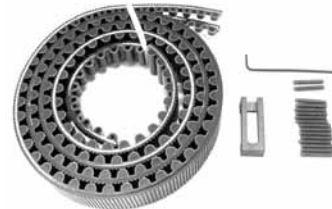

## Rear Belt 'T' Nuts

12628 5 Pack (7669)

## Belt Tension Gauge

Gauge is designed to aid in properly adjusting belt tension on models with a secondary drive belt.

26016



# Replacement Belts

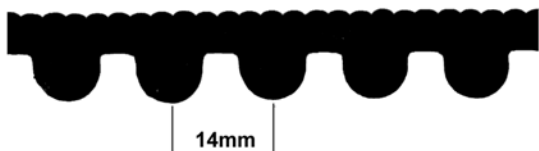

## Dayco Panther 14mm x 1-1/2" Rubber Rear Belts

Dayco	Description
42120	125T
42122	126T (OEM 40003-79)
42123	127T
42124	128T
42126	130T (OEM 40017-94)
42127	132T (OEM 40023-86)
42128	133T (OEM 40015-90)
42129	135T
42130	136T (OEM 40001-85)
42145	139T FLT 1997-03

## Dayco Panther 14mm x 1-1/8" Rubber Rear Belts

For XL models and 2000-05 FXST, Dyna models.

Dayco	Description
42121	125T XL
42125	128T XL
42131	130T
42132	132T
42133	133T
42144	135T
42134	136T
42146	150T 1 3/8" V-ROD 2002-03



## Falcon Rear Drive Belt

The "Falcon" belt by Good Year Engineered Products features a new tooth design for ultimate belt wrap on all stock and aftermarket pulleys which allows maximum strength, alignment and belt life. The Falcon is now standard on all Buell models.

1-1/2"	1-1/8"	Teeth
42136	42137	127
42138	42139	130
42140	42141	132
42142	42143	135

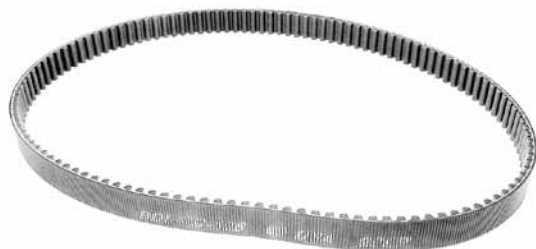

## T/L Heavy Duty Belt Drive 139T x 1-1/2"

Increased strength belt for side car additions.  
42037 All 1997-03 FLT models (40130-03)

**Note:**  
The replacement belts offered for sale on this page have no warranty whatsoever.

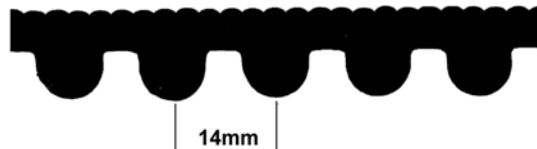

## 14mm x 1-1/2 Poly Rear Belts

Gates	Topline	Description
42110		125T Custom
3210	42040	126T 4 speed 1980-86 FXWG (40003-79)
42111		127T Custom
3212	42042	132T Softail 1986-92 (40023-86)
42080	42045	128T Softail 1993-94 (40012-90)
42088	42046	130T Softail 1995-99 w/65T pulley (40017-94)
42079	42043	133T Dyna-Glide 1991-99 (40015-90)
42077		135T Custom
3211	42041	136T FLT's 1985-96, FXR 1985-94 (not FXST-Dyna) (40001-85)
42112	42049	139T FLT 1997-03 (40024-97)
42150		139T FLT 2004-06 (40024-04)

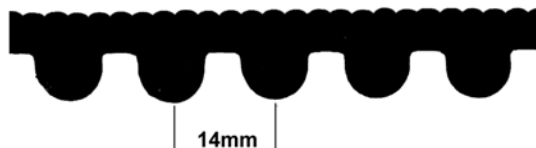

## 14mm x 1-1/8" Poly Rear Belts

Gates	Topline	Description
42078	42048	125T XL (40038-91)
42076	42044	128T XL (40022-91)
42113	42050	130T XL (40047-98)
	42158	131T Dyna 2007-09 (40046-07)
42114		132T
42115	42039	133T 2000-06 Dyna (40015-00)
42116	42038	135T 2000-06 Softail (40307-00)
	42151	135T 2006 FXST/B/S/SI, FXSTI, FXSTBI (40655-06)
42117	42152	136T XL 883 2004-06 (40570-04)
	42153	137T XL 1200 2004-06 (40571-04B)
42118		139T
	42047	V-Rod (40027-01)

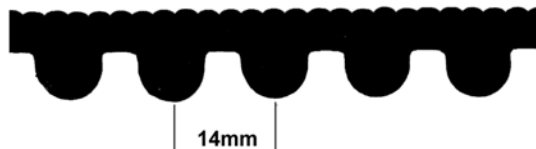

## 14mm x 1" Poly Rear Belts

PCP	Description
42154	137T FLT 2007-on (40024-07)
42155	133T 1" FLST/N/F, FXCWC,FXST/C,(40058-07)
42156	133T 20mm wide (40073-07)

.....  
 • **Note:** All belts by Primo, Falcon or BDL are manufactured  
 • by Gates Rubber, Goodyear or Dayco Panther.  
 • Belts **do not** carry any warranty, of any kind, whether sold  
 • separately or in a complete kit.  
 .....

# BDL

## BDL Top Fuel Street Drive Belt Drive 1991-05

Top Fuel Street Drive features an all new clutch design and an all aluminum, hard-anodized hub for superior strength. The clutch consists of varying spring pressure to accommodate any size motor on the market. Two different kits are available with both being designed for oil filter mounting in the motor plate. Replacement belts measure 14mm x 85mm wide (3-3/8").

### Top Fuel Drive with Side Guard

This kit is a complete drive with a side guard for Softail models 1991-05.

**76487** (TF-1000)

### Top Fuel Drive with Bearing Support 1991-05

This kit is a complete drive with an outboard bearing support. The outboard support plate is reversible and features 2 designs. The back side features polished flat surfaces and channels for a distinctive look.

**76488** (TF-2000)

**42099** Replacement belt 14mm x 85mm wide (3-3/8")

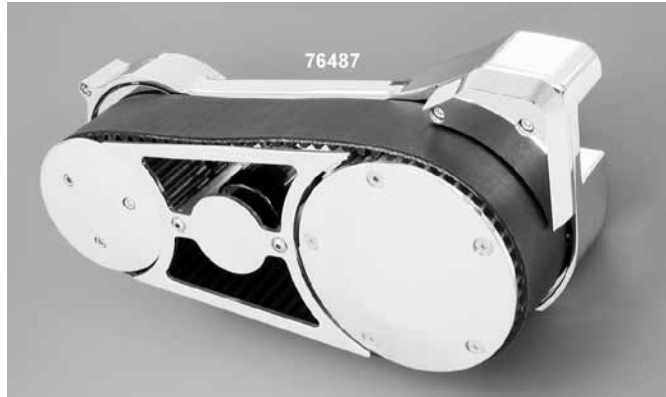

## Falcon SPC (Sport Plus Carbon) 14 MM Belts

Carbon fiber-reinforced, Goodyear engineered Falcon SPC belts off OEM Quality. With up to 33% more tensile strength than conventional aramid-reinforced belts, longer belt life can be achieved without sacrificing performance. Specifically designed as a secondary drive belt for motorcycles and produced in the USA, this high-temperature rubber compounded belt provides excellent flex and service life. Featuring a patented fabric-reinforced tooth surface that can increase horsepower and improve wear resistance. This durable material composition is designed to sustain belt-penetrating debris without breakage. Available in 1-1/2", 1-1/8", 1" and 20mm widths.

20mm		
PCP	Teeth	Width
42225	132	20mm
42229	133	20mm
42233	135	20mm

1"		
42221	130	1"
42224	132	1"
42228	133	1"
42232	135	1"
42236	136	1"
42237	137	1"
42240	139	1"

1-1/8"		
42212	125	1-1/8"
42214	126	1-1/8"
42216	127	1-1/8"
42218	128	1-1/8"
42220	130	1-1/8"
42223	132	1-1/8"
42227	133	1-1/8"
42231	135	1-1/8"
42235	136	1-1/8"
42239	139	1-1/8"

1-1/2"		
42211	125	1-1/2"
42213	126	1-1/2"
42215	127	1-1/2"
42217	128	1-1/2"
42219	130	1-1/2"
42222	132	1-1/2"
42226	133	1-1/2"
42230	135	1-1/2"
42234	136	1-1/2"
42238	139	1-1/2"

.....  
 : **Note:** All belts by Primo, Falcon or BDL are manufactured :  
 : by Gates Rubber, Goodyear or Dayco Panther. :  
 : Belts **do not** carry any warranty, of any kind, whether sold :  
 : separately or in a complete kit. :  
 : .....

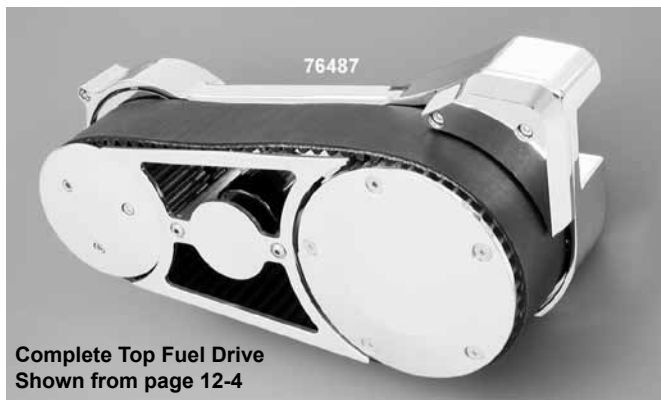

Complete Top Fuel Drive  
Shown from page 12-4

## BDL Top Fuel Drive Replacement Parts

PCP	Description
76191	Bearing covers for outboard support TF-2000 (pair)
76192	Bearings for outboard support TF-2000 (pair)
76193	Spline hub for TF drives (TFCH-180)
76194	Front pulley for TF drives (TFFP-30)
76195	Front pulley cover for TF-1000 (TFFPC-1000)
76196	Front pulley cover for TF-2000 (TFFPC-2000)
76197	Hardware kit for TF-1000 (TFHK-1000)
76198	Hardware kit for TF-2000 (TFHK-2000)
76199	Motor plate with bearing for TF drives(TFMP-100)
76200	Rear pulley basket for TF drives(TFRP-46)
76201	Rear pulley cover for TF-1000 (TFRPC-1000)
76202	Rear pulley cover for TF-2000 (TFRPC-2000)
76203	Side guard for TF-1000 (TFSG-1000)
76204	Standard outboard support for TF-2000 (TFSG-400)
76205	Starter housing for TF drives (TFSH-100)
76206	Pressure plate for TF drives (TFSS-PP)
76207	Clutch friction plates (set of 9) (TFSS-CP)
76208	Clutch steels (set of 11) (TFSS-CS)
76209	Clutch shoulder bolts (set of 9) (CDSB-100)
76210	Clutch springs (set of 9) (CDCS-100)
76424	Ring gear only (SG-2)

Note: PCP #76209 and 76210 are the same as the BDL chain drive.

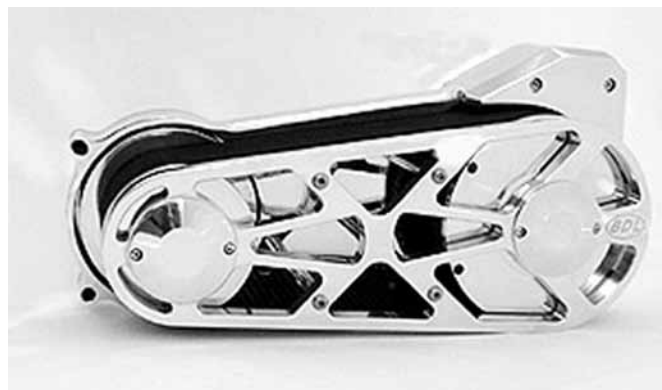

## BDL Complete 3" Drive with Outboard Support

Accepts 1990-06 starter. (no oil filter in inner cover)

PCP	Application
76507	1986-89 Softai (EVO-900T)
76508	1990-04 Softail (EVO-900)
76510	1991-98 Dyna (EVO-1200)

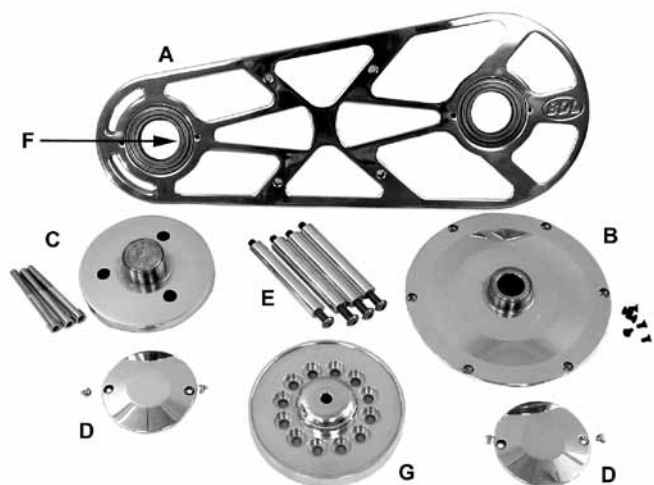

## BDL Outboard Support Retrofit Kit

Support kit fits all three of BDL's 1990-05 Softail and 1990-05 Dyna drives. **Modifications to front and rear pulleys are required** and instructions are included.

Kit	76506	Complete retrofit kit (EVO-3000, as shown)
A	76512	Support plate (EVO-3000SP)
B	76181	Rear pulley cover (EVO-3000RC)
C	76182	Front pulley cover (EVO-3000FC)
D	76183	Bearing covers (pair) (EV)-3000BC)
E	76184	Stand-offs (4 pack) (EVO-3000SO)
F	76192	Sealed bearings (pair) (TFBSB-100)
G	76186	Pressure plate (EVO-3000PP)

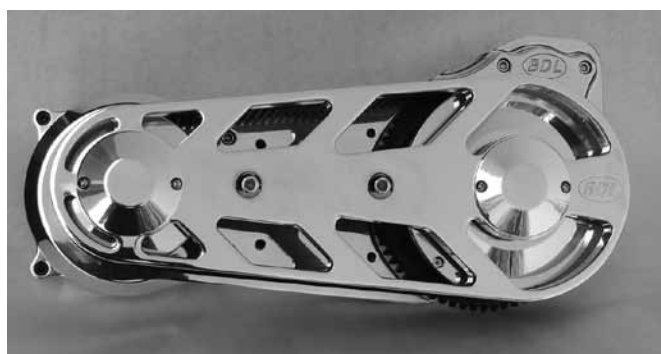

## 3" Belt Drive with Upgraded Outboard Support

Which adds increased rigidity and keeps the transmission shaft from Flexing under load. This NEW design is a must for wide tire high horsepower applications. This kit includes the new patented Ball Bearing lock-up clutch for positive engagement

PCP	Application
76509	1990-2006 Softail (EV-950)

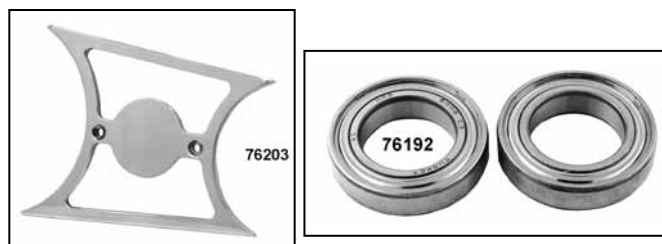

# BDL

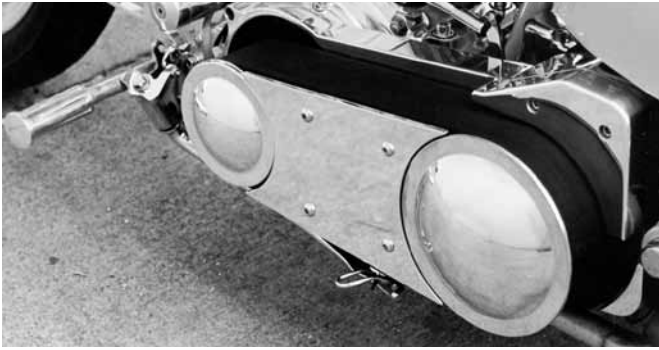

## BDL 8mm 3" Electric Start Belt Drives

Belt drive kits include a polished one piece 6061-T6 billet motor plate and complete belt drive with pulley cover. For added mainshaft support a double row sealed bearing is used. Clutch basket has 12 cylindrical replaceable clutch dogs which allows the steels to maintain constant contact for quieter operation. Polished pressure plate uses 6 shoulder bolts and springs. The "Competitor Clutch" features Kevlar clutch plates for maximum performance. The plate is recessed to hide starter ring gear which is covered by a polished aluminum starter housing. Also includes a polished aluminum side guard.

PCP	Application	Belt #
76330*	Softail 1986-89 (EVO-9T)	42068
76332	Softail 1990-06 (EVO-9S)	42068
76334	FXR/FLT 1990-99 (EVO-11S)	42069
76335	Dyna 1991-99 (EVO-12S)	42068
76434	Mini dome cover for above kits. Has special tape for bolt-less installation and button bolts for on and off installation (MD-100)	

\* Note: this model must use 1991 and later starter and some modifications will be necessary to install the starter.

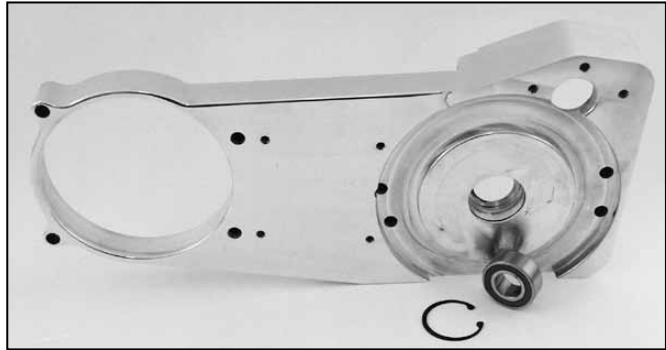
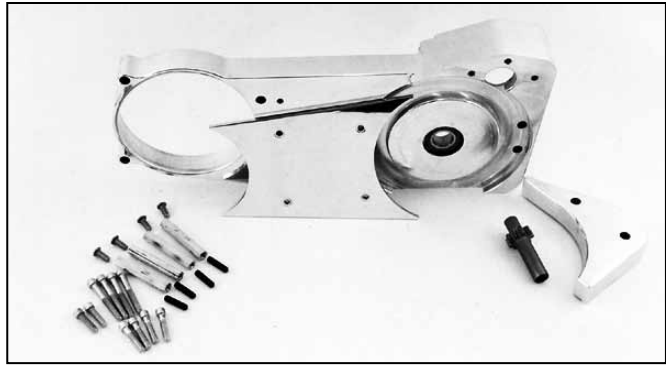

## BDL 3" Electric Start Complete Motor Plate Kit

PCP	BDL	Application
76344	BDL-900P	Softail
76346	BDL-1100P	FXR
76347	BDL-1200P	Dyna Glide



## Retrofit Clutch Kit (Stock on Super Street kits)

Includes basket, hub, clutch and pressure plate. This kit allows the retrofit of all EVO-9S, EVO-11S and EVO-12S kits.  
76473 (SS9RFK)

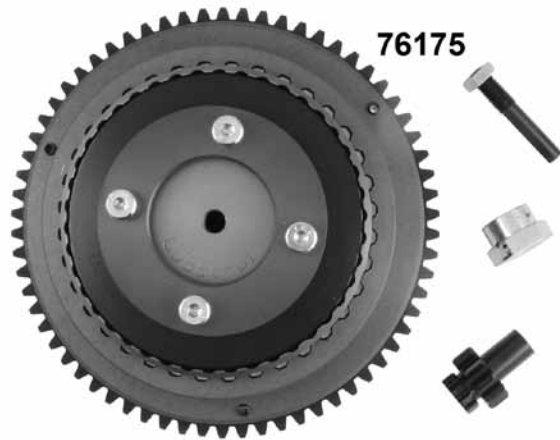

## BDL Chain Drive with Ball Bearing Lock Up Clutch for 1998-06 Big Twin Models

Ball bearing clutch basket features a pressure plate that uses 5/16" steel ball bearings, diaphragm, retainer and adjusting screw. For larger engines it may be necessary to use carbide balls.

PCP	Description
76175	Complete clutch basket (less chain) (CDB-2-90)
76176	Clutch basket and chain kit includes complete clutch basket, adjuster shoe with bracket, Diamond primary chain and 25T front sprocket (CDB-1-90)
76177	Clutch basket and compensator kit includes complete clutch basket, adjuster shoe with bracket, Diamond primary chain, 25T front sprocket and BDL compensator (CDBCS-1-90)

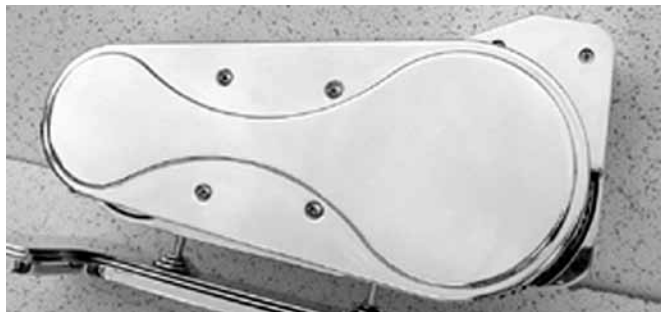

### Belt Drive Covers for 3" FXST

Chrome covers add a stylish custom look by covering the belt drive on 3" Softail kits.

**PCP**    **Finish**

**Solid Design**

**76357**    Chrome (BDC-3C)

**Large Hole Design**

**76353**    Chrome (BDC-1C)

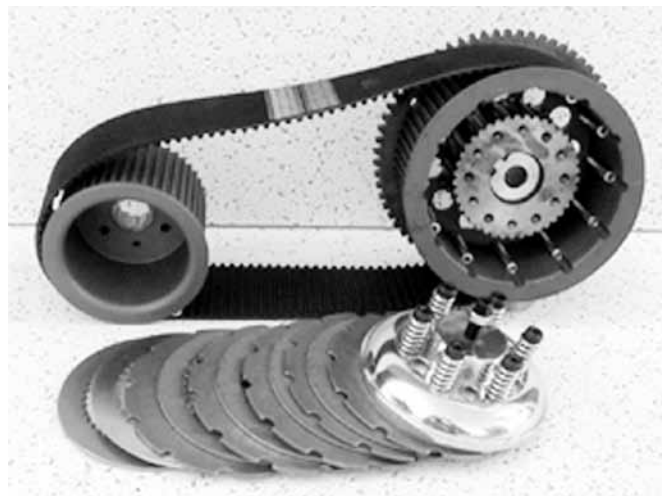

### 3" Electric Start Wide Drive Kits Softail 1990-05

Kits include everything shown as well as an offset front pulley and primary spacer.

**PCP**    **Description**

**76481**    3" kit with 1/2" offset (EVO-9SW-500)

**76482**    3" kit with 3/4" offset (EVO-9SW-750)

**76483**    3" kit with 1" offset (EVO-9SW-1000)



### Replacement Parts for 3" Open & Closed Drives

**PCP**    **Description**

**76187**    Pressure plate (EPP-100)

**76188**    Clutch adjusting rod 1990-on (CDAS-100)

**76189**    Shoulder bolts (6 pk) (ESB-100)

**76190**    Clutch springs (6 pk) (ECS-100)



### BDL 3" Replacement Basket

Includes basket, gear, dogs and bearings. 72 Teeth by 3" with a bolted-on 66T ring gear.

**76299**    FXST, FXR, Dyna (72-3E)

**76424**    Starter ring gear only (SG-2)



### BDL 9T Starter Pinion Gear

Replacement parts for 3" electric start.

**PCP**    **Application**

**76211**    All Softail, FXR and Dyna 3 1/4" OAL (PG-100)

**76214**    FXST 1994-on closed 1 7/8" OAL (PG-300)

# BDL



## 2 3/4" Open Belt Drive For 07-09 Softail & Dyna

The Polished ALL-NEW EVO-8S 2 3/4" belt drive fits 2007-2009 Softail and Dyna models. Also included in this drive kit is BDL's NEW ball bearing lock-up clutch system! Other features include a specially designed ring gear for easy starting and a 59T front pulley and a 69T rear pulley, both 69mm wide and driven with a specially designed 142 T belt.

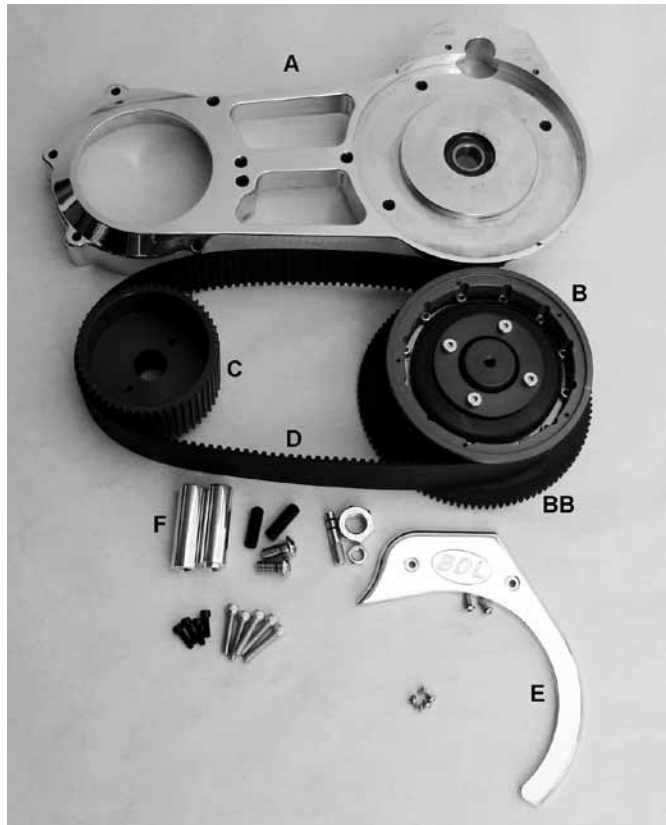

Kit	<b>76517</b>	EVO-8S Belt drive kit (polished)
A	N/A Separately	Motorplate for EVO-8S
B	<b>76171</b>	Rear pulley 69 tooth/69mm wide
BB	<b>76215</b>	Ring gear SG-4
C	<b>42091</b>	Front pulley 52 tooth/69mm wide
D	<b>42157</b>	142 Tooth belt/69mm wide
E	<b>76216</b>	Starter housing and guard
F	<b>76217</b>	Stand-offs with hardware
G	<b>76173</b>	Side guard
H	<b>76174</b>	Rear pulley cover

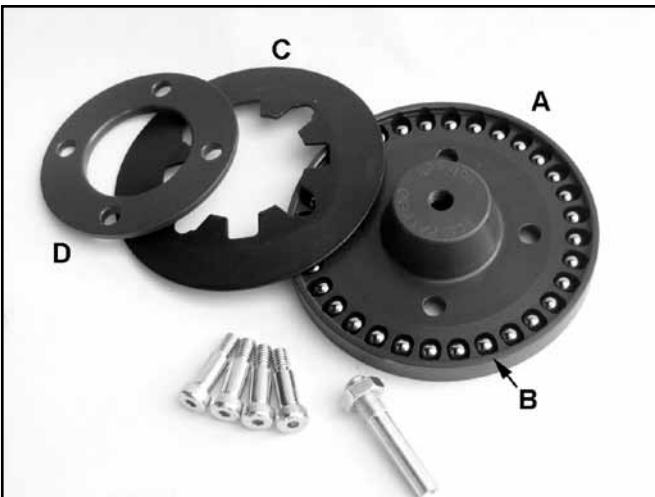
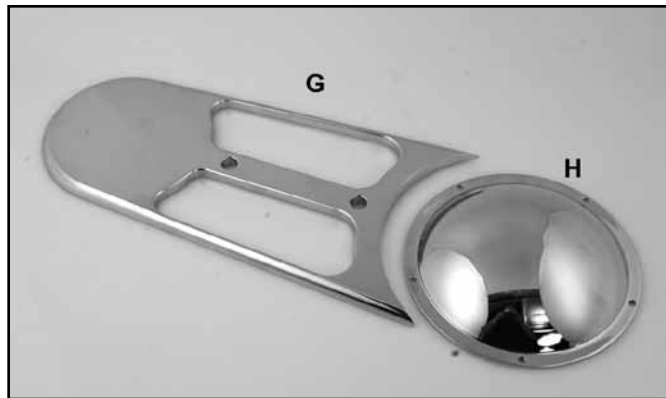

## BDL Ball Bearing Pressure Plate Kit

Kit	<b>76169</b>	Complete kit
A	<b>76218</b>	Pressure plate
B	<b>76219</b>	3/8" Ball bearings (32 pack)
C	<b>76220</b>	Diaphragm spring
D	<b>76221</b>	Spring retainer
Uses 4-3/8 x 7/8 Socket head shoulder bolts		



## BDL Standard Clutch Kit

<b>76600</b>	Set of 7 Fiber plates	ERCP-100
<b>76601</b>	Set of 7 Steel plates	ERCS-100
<b>76452</b>	Backing plate (each)	EDP-200
<b>76604</b>	Complete kit	ERCPS-100

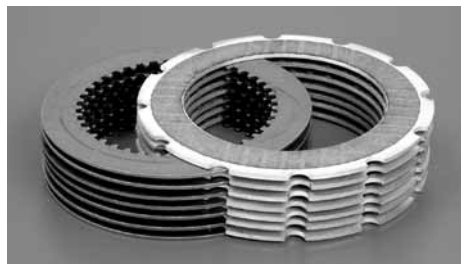

### BDL Standard "Quiet" Clutch

<b>76600</b>	7 Fiber plates (ERCP-100)
<b>76601</b>	7 Steel plates (ERCS-100)
<b>76452</b>	Backing plate (EDP-200)

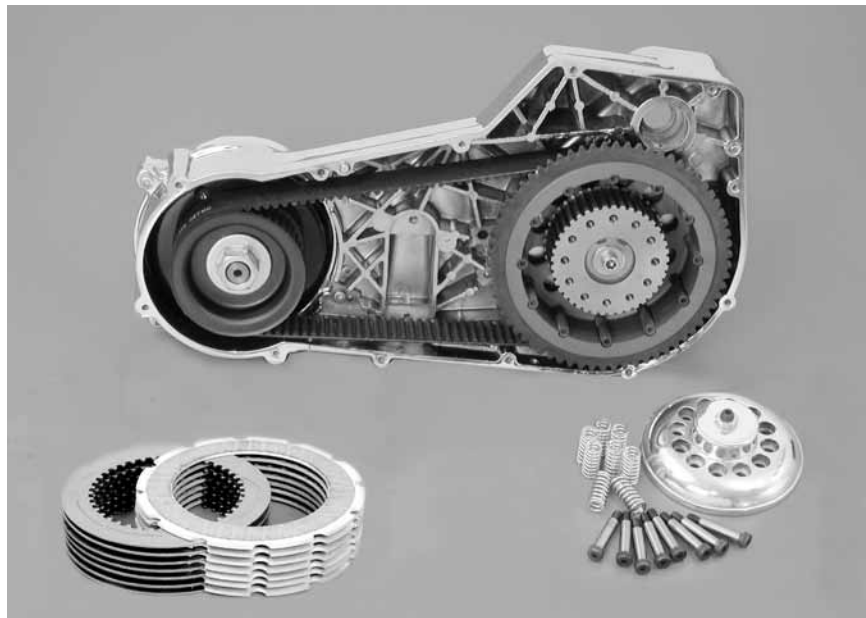

**76168**

### BDL Closed Primary Belt Drives For Big Twins 1 5/8"

Closed belt drives for Softail, Dyna, and FXR. Designed for a bolt-in application. Our clutch basket features 12 cylindrical replaceable clutch dogs, which allows our clutch steels to maintain constant contact. The polished pressure plate uses nine shoulder bolts and springs, which allows simple installation. Our Kevlar clutch plates give maximum performance. We include a sealed bearing for the inner primary for 1986 & Up belt drives.

### BDL Replacement Hubs

PCP	Description
<b>76048</b>	1986-89 w/taper shaft for #76310/76313 (EV-170)
<b>76168</b>	1990-on w/splined shaft for #76311/76314 (EV-180)

PCP	Pulley	Description (with Quiet Clutch)	Year	Belt
<b>76310</b>	68-47	FXR, FLT (EVB-1T)	1986-89	<b>42059</b>
<b>76311</b>	68-47	FXR, FLT (EVB-1S)	1990-93	<b>42059</b>
<b>76312</b>	68-47	FXR, FLT with pinion gear (EVB-1SL)	1994-on	<b>42059</b>
<b>76504</b>	Replacement 48T front pulley for above FXR, FLT models (does not use belt guides) (48EVB)			
<b>76313</b>	68-45	Softail (EVB-2T)	1986-89	<b>42062</b>
<b>76314</b>	68-45	Softail (EVB-2S)	1990-93	<b>42062</b>
<b>76315</b>	68-45	Softail with pinion gear (EVB-2SL)	1994-on	<b>42062</b>

Note: All above units are for rear belt drive model Big Twins

\*All above units are supplied with only 1 Kevlar belt and there are no returns or exchanges on belts

\*\*Due to model changes in 1984 and early 1985, belt drives for these model years are not available

### Alternator Cover

Polished aluminum alternator cover for 3" open drives.

**76444**

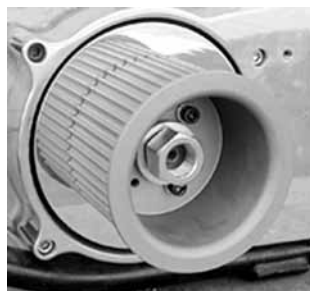

### BDL 45T front 1 5/8" pulley

**76465** For #76313 (45-OFP)

**76474** For #76314 & #76315 (45EV)

# BDL

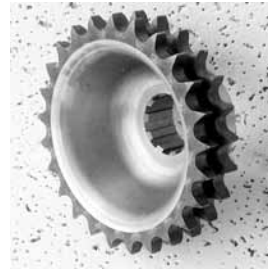

## BT Rear Wheel Spacers (BDL)

PCP	Size	BDL
76427	.250"	RPS-0250
76428	.375"	RPS-0375
76429	.500"	RPS-0500
76430	.750"	RPS-0750
76431	.937"	RPS-0937 for use with BDL 1" pulley
76418	15/16	RPS-100
76432	1.100"	RPS-1100 for use with CCI wheels
76433	1.250"	RPS-1250

## BDL 1/2" & 1" Offset 25 Tooth Front Sprocket

Sprocket fits FXST 1991-on

76180 1/2"

76417 1"

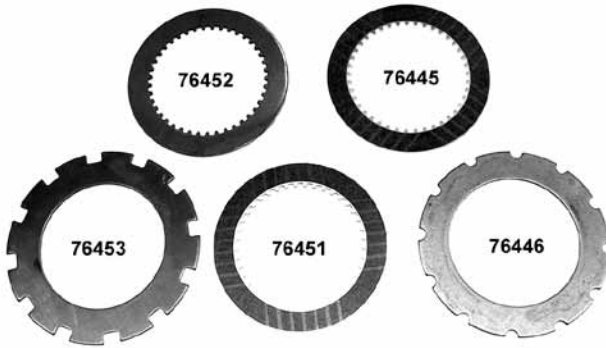

## BDL Ring Gear

76424 Ring gear only BT 1985-93 for all BDL closed primary drives with BDL clutch

76425 Starter ring and pinion gear for all BDL closed primary drives with BDL clutch using 1994-on starter



## BDL Clutch Plates- Sold Each

PCP	Application
76445	Kevlar 1 sided (ECP-100-1)
76446	Steel plate for round dogs (ERDS-100)
76451	Kevlar 2 sided (ECP-200-2)
76452	Splined steel (EDP-200)
76453	Steel for square dogs (EDP-100)

## BDL Quiet Clutch Plates

76600 Kevlar (7 pack)

76601 Steel plates (7 pack)



## Chrome BT Alternator Rotor Cover 1981-on

Cover presses over 1981-on rotors for a tight fit.

45397



### BDL Complete Primary Chain Drive Competitor Clutch

Kevlar clutch provides 60% more clutch surface than stock and the 9 spring pressure plate provides all the spring pressure needed for stock to strokers. Competitor clutch provides transfer of power to the rear wheel. Kits include 25T front sprocket, rear basket with Competitor Clutch, primary chain and adjuster assembly.

PCP	Description
76303	BT 1986-89 (CD-1-86)
76304	BT 1990-on (CD-1-90)

### BDL Chain Drive Competitor Clutch Basket

Kevlar clutch provides 60% more clutch surface than stock and the 9 spring pressure plate provides all the spring pressure needed for stock to strokers. Competitor clutch provides transfer of power to the rear wheel. Stock components will work with these drum assemblies. (requires 25T sprocket)

PCP	Description
76307	Softail, FXR, FLT 1986-89 (requires 25T sprocket)
76308	As above for Softail, FXR, FLT 1990-on (CD-2-90)
76309	Chain drive electric start rear basket only (no clutch) for Softail FXR, FLT 1990-on (CD-3-90)

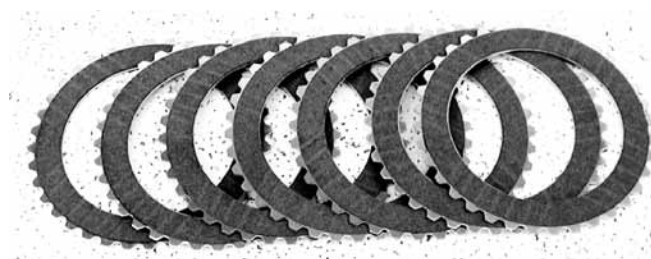

### Kevlar Clutch Pack for Chain Drive

Set of 7 plates which can also be used with BDL competitor clutches.

76454 (CDCP-100)

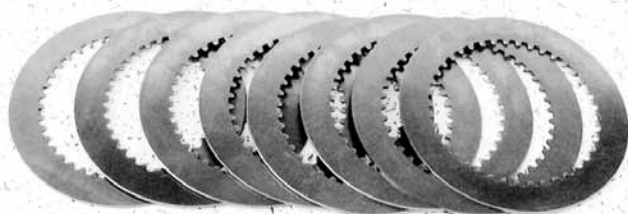

### Steel Drive Plates for Chain Drive

Set of 8 drive plates.  
76455 (CDDP-100)

# BDL



## BDL "Competitor Clutch"

Features 9 springs and shoulder bolts for easy spring adjustment. A large 40mm double row hub bearing provides maximum performance and strength. The polished pressure plate adds a custom touch for open belt drive installations. Also includes a race proven Kevlar clutch.

**76421** EVO BT chain primary 1990-97 (CC-120-E)



## Replacement Clutch Fibers and Steels

**PCP Description**

**76448** Set of 7 steels (CC-100-CS) for #76421

**76447** Set of 5 fibres (CC-100-CP) for #76421



## BDL Ultimate Clutch Kit

This high performance clutch lets you choose between a diaphragm or coil spring application. Our new kit will fit any BDL belt drive open or closed. Kit includes 2 diaphragm springs, spring collar, 12 springs and shoulder bolts.

**76505** (UC-1000)



## BDL Chain Compensator BT 1980-06

**76179** 24T (CS-24A)

**76475** 25T (CS-25A)



## Auto Slip Clutch

Fits all BDL belt drive units.

**21780**

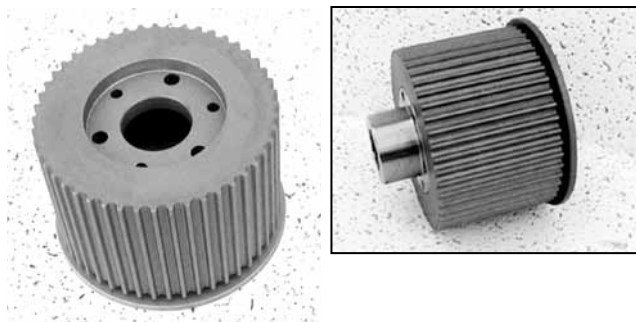

### BDL Offset Front Pulleys with Standard Nuts

PCP	Description
76465	1-5/8" 45 T pulley for FXST w/ standard nut
76466	3" 47T pulley for FXST w/standard nut
76467	3" 48T pulley for FXR w/standard nut



### BDL Polished Primary Spacers

PCP	Size	PCP	Size
76456	1/4"	76500	1.250"
76457	1/2"	76501	1.500"
76458	3/4"	76502	1.750"
76459	1"	76503	2.000"



### Sealed Clutch Drum Bearing 1985-on

For belt drive applications on Big Twins.

PCP	Years
15755	1985-90
15756	1991-06



### BDL Pulley Inserts

PCP	Description
76468	1/4" insert and special nut with screws
76469	1/2" insert and special nut with screws
76470	3/4" insert and special nut with screws
76471	1" insert and special nut with screws
76472	1-1/4" insert and special nut with screws
76479	1-1/2" insert and special nut with screws
76493	2" insert and special nut with screws



PCP	Description
76439	Inside belt guide (1BG-1)
76440	Outside belt guide (OBG-1)
76441	Flat hex nut for spline shaft
76442	Washer for spline shaft



### BDL Idler Bearing Kit

76437 (IBK-1)



# Belt Drive Accessories



## Pulley Spacers 1980-99

Provides an offset when required with 7/16" bolt holes. Each disc measures 2-1/16" I.D. with 4-5/16" O.D.

PCP	Thick	Material
3376	1/16"	Steel
11855	3/16"	Steel (.200)
73639	3/16"	Billet
11856	1/4"	Billet
11857	5/16"	Billet
11858	3/8"	Billet
11859	1/2"	Billet
11865	5/8"	Steel

## Front Pulley Spacers 2000-on (each)

PCP	Thickness
11866	1/16"
11867	.125"
11862	.200
11863	.250
11864	.300
11887	.500
11888	.750
11889	15/16"
11890	1"
11891	1-3/8"
11892	1.5"



## BT 5 & 6 Speed Bearing Support Plate 1984-00

Fits 1984-2000 BT models with kickstart. Billet aluminum support plate includes bearing.

21778

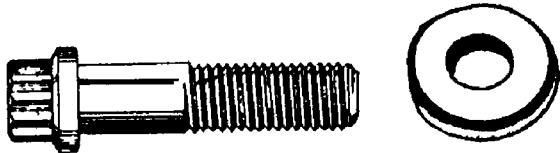

## BT 12 Point Pulley to Wheel Mount Bolts

Includes washers

PCP	Description
21508	1984-86, 1991-on wire
21509	1987-90 wire
21510	1987-on cast

## Button Head Screws

5 piece set for rear belt pulleys on 1981-up FXSB, 1984-up FXST-FLST. Replaces 3771. Includes TORX socket.

24020	Kit
24021	Screws and washers only

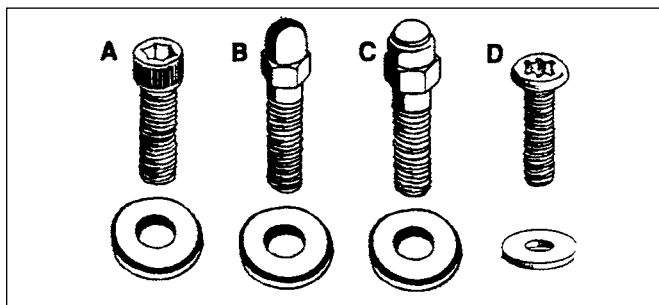

## Rear Belt Pulley Bolt Kits

For cast or 1985-on FXWG-FXRS with wire wheel and using OEM 4726 bolts.

Type	Cast	Wire	Style
A	4371	4367	Allen
B	4369	4363	Acorn
C	4370	4366	Cap

## D Button Head Screws

For rear belt pulley on FXSB 81-\*, FXST-FLST 84-\*. 5 Piece set includes TORX socket.

24020 Replaces 3771

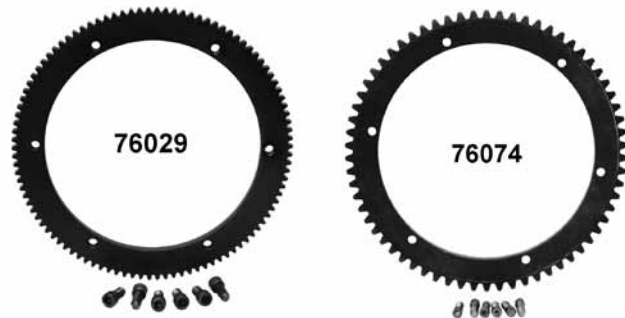

## Primo Starter Ring Gears For Belt Drives

Designed to replace Primo gears on all Big Twins.

PCP	Application
76074	66T for Brute IV (pp-118-3-66) and for Primo TC
76029	For 1994-on Brute III 102T belt drive baskets (PP-118-EVOL)

# BDL Rear Wheel Pulleys

## BDL Rear Aluminum Pulleys

Made from 6061 billet aluminum, CNC machined and highly polished or show chromed. Pulleys feature gear cut teeth to RMA standards that prevents premature belt and pulley wear.

## Polished Pulleys



**Plain Design**  
**PCP Description**  
**76380** 65T 1-1/2" wide  
**76381** 70T 1-1/2" wide



**5 Hole MR Design**  
**PCP Description**  
**76388** 65T 1-1/2" wide



**9 Spoke Design**  
**PCP Description**  
**76392** 70T 1-1/2" wide



**Mesh Design**  
**PCP Description**  
**76391** 70T 1-1/2" wide



**3 Spoke**  
**PCP Description**  
**76382** 65T 1-1/2" wide  
**76383** 70T 1-1/2" wide



**3 Spoke Swept Wing Design**  
**PCP Description**  
**76386** 65T 1-1/2" wide  
**76387** 70T 1-1/2" wide



**Domed Bolt Covers for Flat Pulleys**  
 Covers can be installed on any flat pulley and are available in chrome or polished.  
**76415** Polished  
**76416** Chrome



## Chrome Pulleys



**Plain Domed Billet Pulley**  
**PCP Application**  
**76369** 70T 1-1/2"



**Sunburst Domed Billet Pulley**  
**PCP Application**  
**76361** 70T 1-1/2"



**5 Spoke Domed Billet Pulley**  
**PCP Application**  
**76377** 70T 1-1/2"



**Swept Domed Billet Pulley**  
**PCP Application**  
**76373** 70T 1-1/2"



### Chrome Rear Pulley Bolt Cover

Designed to fit all pulleys. Unique design allows the mounting bolts to be covered for a cleaner style.  
**45359**

# Rear Wheel Pulley

65522

65521



37237

59225



## BT Rear Drive Pulley 1.5" Wide to 1999

PCP	Teeth	OEM	Years
37238	61	40236-88A	1988-99 (silver)
37237	65	Chrome	1988-99
37229	70	Chrome	1980-99
59225	70	Silver	1980-99 (silver)



65540



65538

## T/L Stock R/Wheel Belt Pulley BT 2000-\* USA

Bolts to standard rear 5 bolt pattern. 70T Stock ratio is 2.187 on 5 speeds. Stock finish as factory.

PCP	Application
65516	70T Black Softails 2000-05, not Deuce (40289-00)
65517	70T Silver Softails 2000-05, not Deuce(40295-00)
65543*	70T Black FXST/S/SI/B/BI 2006 (40599-06)
65544*	70T Silver FXST/S/SI/B/BI 2006 (40606-06)
65536*	66T Black FXST/B/C 2007-10 (37710-07)
65537*	66T Silver FXST/B/C 2007-10 (37711-07)
65538*	66T Black FLSTC/S/N 2007-10 (40325-07)
65540*	66T Silver FLSTF 2007-10 (40690-07)
65533	70T Silver Softail Deuce 2000-06(40303-00)
65539*	66T Black Softail Deuce 2007 (40661-07)
65518	70T Black FLT 2000-03 (40217-00)
65532	70T Black FLT 2004-06 (40217-04)
65541*	66T Black Touring 2007 (40217-07)
65521	70T Black Dyna 2000-05 (40114-00)
65522	70T Silver Dyna 2000-05 (40221-00)
65530	70T Black Dyna 2006 (40576-06)
65531	70T Silver Dyna 2006 (40578-06)

\*OEM stock style holes



65502



65503

## T/L Stock 1.5" Rear Wheel Belt Pulley USA

Bolt to standard rear 5 bolt pattern. Stock ratio 2.121 on 4 speeds, 2.187 on 5 speeds.

PCP	OEM	Teeth	Finish	Model
65500	40221-85A	70T (Topline)	Stock-silver	BT 5-speed
65502	40217-79A	70T (Topline)	Stock-black	BT 5 & 4 spd, 84-on FXWG
65503	40311-94	65T (Topline)	Stock-silver	94-99 5-spd
65504	40312-94	65T (Topline)	Stock-black	94-99 5-spd
65512	40236-88A	61T (Topline)	Stock	BT 5-speed
65501	40213-91	61T (Topline)	Stock	91-99 XL 5-sp
65511	40252-91	55T (Topline)	Stock	91-99 XL 5-sp

## Pulley Adaptor Ring

Will adapt the 2000-on 1.125" wide types to 1999 and earlier wheel hubs, which will allow use of a 170 mm wide tire on 1999 and earlier applications.

59133



## Rear Sprocket Bolt Cover Kit

Kit includes 5 chrome plated covers with internal spring clips to hide the stock sprocket bolts on 1993-on Softail, 1999-on Touring, and 2004-on XL models with stock 7/16" hex sprocket mounting bolts.

29677 43876-04

# Rear Wheel Pulley



## 70T Pulleys FLT 2000-03

Features 1-1/2" width with 2-1/4" centre hole to fit with hubs with 1" bearings.

**PCP Style**  
**59867** Holes



## Billet Chrome Rear Pulley BT 2000-on

Fits 2000-on with 1.125 width belt and 70 tooth ratio.

**PCP Style**  
**59253** 8 spoke FXST 2000-06  
**65529** 3 spoke Dyna 2000-05 (40148-02)  
**65527** 3 spoke FXST 2000-06 (40455-02)



## Polished Pulley Spacers

Use these threaded spacers to adapt pulley to hub. This version offers extra support by mounting with 2 sets of bolts.

2000-on	1980-99	Thickness
11874	11880	1/2"
	11881	3/4"
-	11882	11/16"
	-	15/16"
	11883	1"
-	11884	1.25"
	11885	1-3/8"
	11886	1.5"



## Billet Chrome Rear Pulley BT 2000-05

Fits 2000-05 with 1.125 width belt and 70 tooth ratio.

**PCP Style**  
**59306** 5 spoke FXST (40508-00)  
**59307** 6 spoke FXST (40447-01)  
**65528** 6 spoke FXD (40451-01)



## 2000-on Pulley Bolt Kits

**PCP OEM Type**  
**24099** 43245-00A Allen  
**24102** 94773-90A Hex

## Chrome XL 1.125 Wide R/Drive Pulley

PCP	Teeth	Years
21837	61	1991-99
59255	61	2000-03
21838	61	2000-03
59492	61	2004-06
21839	68	2004-06, 18 spoke

# Rear Wheel Pulley

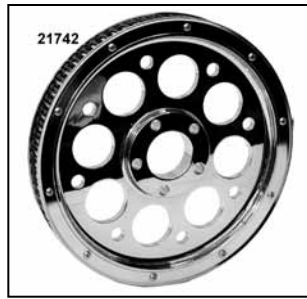

## Chrome BT 70T Rear Drive Pulleys

PCP	Width	Application
21742	1.125"	FXD 2000-05
21745	1.125"	FXD 2006
21743	1.125"	FLT 2004-06
21744	1.125"	FXST 2006

## Chrome Maltese Cross BT Rear Billet Pulleys

PCP	Tooth	Year	Width
59314	70	1980-99	1.5"
59315	65	1986-99	1.5"
59316	70	2000-06	1.125"



## Sportster 61T Models 2000-06

65525 40213-00

## Chrome BT 1986-on Billet Rear Pulley

Features 18 spoke design and will accept to a 1.5" belt.

PCP	Tooth	Years	Width
59312	65	1986-99	1.5
59313	70	1986-99	1.5
59636	70	2000-06	1.125
59965	65	2-1/4" ID	1.5"
59966	65	2-1/4" ID	1.125"



## Pulley Adapter Flange

3/8" Flange allows the use of late model 1-1/8" wide pulley on early wheel. 1/4" Flange allows the use of any combination of early or late wheel pulley or sprocket.

PCP	Size
11893	3/8" (3 pcs)
11894	1/4" (2 pcs)

## Billet Pulley/Disc Spacers

Fits 2002-on front or rear hubs

PCP	Size
11868	.500"
11869	.750"
11870	.937"
11871	1.10"

## Chrome Billet Laser Style BT Pulleys

PCP	Year	Tooth	Width
59827	1986-99	70	1.5"
59828	1986-99	65	1.5"
59829	2000-06	70	1.125"

# Rear Pulley Cover



## BT 2000-on Style 70T Rear Pulley Cover

PCP	Application
45814	FXST 2000-06
45816	FXD 2000-05 (91346-00)
65515	T/L FXD 2000-05 (91346-00)
45820	FLT 2000-06



## Chrome Sprocket Covers 2000-on

65513	8 Oval holes 2000-06 T/L (91347-00)
45814	As above Preston
65519	8 Oval holes Softail and 2007-on Touring T/L (37757-07)
65514	Duece style cover Softail 2000-06 T/L (91348-00)
45815	As above Preston
65534	T/L 8 Oval hole Dyna 2006 (40595-06)
65535	8 Oval hole T/L Dyna 2007-09 (37756-07)



## Twister Sprocket Cover

Chrome custom sprocket cover easily bolts on using the stock hardware.

65520 40150-08



## Chrome Belt Drive Pulley Insert Kits

Top-quality chrome-plating on formed 'deep dish' steel rear wheel belt pulley inserts. Sprocket insert kit includes a set of chromed button head Torx fasteners and 3/8" drive Torx bit.

### PCP Description

45008	Complete with hardware 8 holes Dyna 1991-99, FXD 1999, 1980-on BT w/70T (12 3/4"OD) (91733-85A)
45802	Inner cover, 70T to fit above
45007	Insert only (12 3/4" OD) for 70T FXST, FLST 84-93, Dyna 1991-99 (91740-87A)
45330	Insert only for 61T pulley Softail 1993 11" O.D. .984 deep (40284-90A)
45804	Insert only for 65T Softail 1995-99 (40317-94)
45807	As above with hardware
<b>Solid Inserts</b>	
45005	Insert only (12 3/4") for 70T FXST 1984-00, Dyna 1991-99, all 1980-on w/70T pulley (91740-87A)
45006	Complete with hardware (12 3/4")



## Inner and Outer Chrome Pulley Covers

Chrome covers have holes and are now able to cover both sides of the standard 70T rear drive pulley 1980-97.

45802	Inner
45008	Outer



## XL Chrome Rear Pulley Cover

PCP	Teeth	Year
45331	61	1991-03 (40279-91)
59576	68	2004-on (Preston)
64829	68	2004-on (T/L) (w/raised rib design) (91746-03)

# Transmission Pulleys



29



## Transmission Drive Belt Pulleys-USA-5 Speed

PCP	OEM	Tooth	Type	Model
290290	--	29T (Andrews)	Power	BT 1985-93
290294		29T (Andrews)	Power	BT 1994-06
290300		30T (Andrews)	Power	BT 1985-93
290304		30T (Andrews)	Power	BT 1994-06
37220	40210-85D	32T (Topline)	Stock	BT 1985-E94
65505	40250-94C	32T (Topline)	Stock	BT L94-06
65542	40659-06	32T	Stock	BT 2007-on
290340	--	34T (Andrews)	Overdrive	BT 1985-93
290344		34T (Andrews)	Overdrive	BT 1994-06
3565	--	33T (Karata)	Overdrive	BT 1994-06
65509	40256-89	27T (Topline)	Stock	XL1986-90
65510	40258-89A	61T (Topline)	Stock	XL 1986-90
65507	40202-91B	29T (Topline)	Stock (1200)	XL 1991-03
65508	40285-91B	27T (Topline)	Stock (883)	XL1991-03

## BT 5 Speed Transmission Pulley 1985-06

Stock style, steel, replacement pulleys. Stock size is 32T.

### Imported

#### PCP BT 5 Speed 1985-93

37221	30T
37222	32T (40210-85B)
37223	34T

#### PCP BT 5 Speed 1994-06

37224	32T (40250-94)
-------	----------------

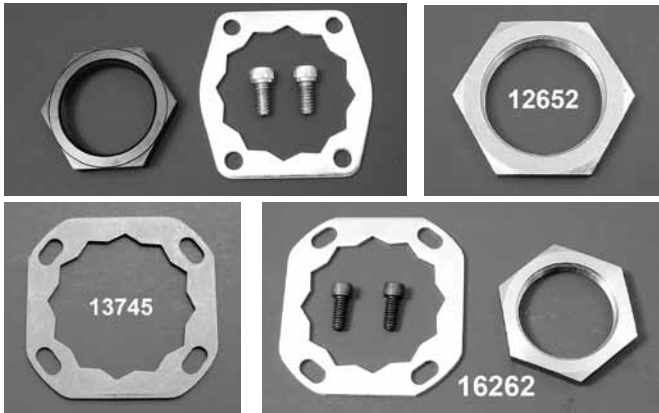

## Front Belt Pulley Lock Plate and Nut Kit

Kit includes: 2 allen screws (35211-91), sprocket lock nut and lock plate (40251-92).

16258	Kit BT 1992-06, XL 1991-08
16262	Kit BT 2007-on, Dyna 2006-on
13741	Lock plate BT 1992-06, XL 1991-08 (40251-92A)
13745	Lock plate BT 2007-on & Dyna 2006-on (35242-06)
12652	Nut only BT 2007-on & Dyna 2006-on (35241-06)
12602	Nut only BT 1991-06 and XL to 2008 (35211-91A)
24567	Set screw 1993-on (3594)

## XL Trans Pulley

29 Tooth pulley for 1991-03.

59494



## BT Front Pulley Spacer Kit

Allows use of 1994-06 front pulley on 1985-93 models.

16330



## BT Drive Pulley Kits

Includes billet pulley which accepts 1.125" or 1.5" wide belts, indexing nut seal and seal spacer.

PCP	Year	Speed	Tooth
21781	1984-93	5	32
21782	1994-06	5	32

## Pulley Indexing 'Mega' Nut

Nut allows drilling and tapping for additional set screw locations.

12629	Preston
31022	Jims



# Outer Primary

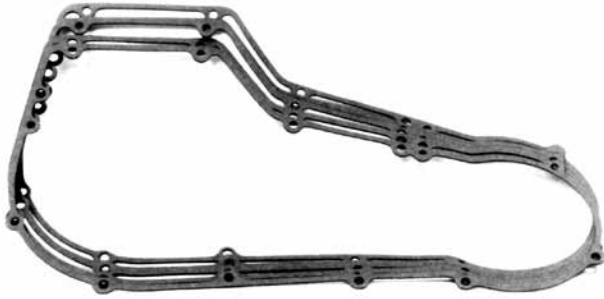

## Primary Cover Gaskets for Big Twins

Replacement primary cover gaskets for Big Twins 1965-up, James Products where noted.

PCP	OEM	Fits
79329	34901-79A	James FLT 85-93 .062 no bead (5pk)
79330	34901-79B	J/Touring 1985-93 (w/silicone) (5 pk)
150239		Gary Bang as above
25153	60538-81A	FXST 82-88,FL/FX 65-on .032 (5 pk)
79417	60531-81-C	James as above (5 pk) w/silicone
150401		Gary Bang .062 9 hole 1965-85
25154	60539-86	FXST 1982-88 (5 pk)
79420	60539-89A	James 89-93 (5 pk) .062 FXST/Dyna
150677		Gary Bang as above
79421	60539-94	James .062 FXST 94-04 silicone (5)
150404		Gary Bang as above
25928	60539-94C	T/L alloy w/silicone as above (each)
79332	34901-94	James .062 w/bead FLT 94-06 (5pk)
150967		Gary Bang, as above no silicone (5)
79740	60547-06	James Softail 07-* & Dyna 06-* (5pk)



## Revolution Chrome Primary Covers (USA)

Primary covers for 5 speed FXR, FLT and Softail® models. Order starter gasket, shaft bearing and mounting screws separately. Top quality.

PCP	OEM	Fits	Year
67650	60543-86A	FXST/S, FLST 9 Hole	1986-88
67655	60665-85B	FXR-FLT/HT	1985-88
67658	60665-99B	FLT's (Touring)	1999-06
67651	60543-89	FXST/S, Dyna, FLST	1989-93
67652	60543-94	Softail, Dyna	1994
67653	60543-95	Softail, Dyna	1995-98
67654	60543-99	Softail Dyna	1999-06 1999-05
67656	60665-89	FXR-FLT/HT	1989-93
67657	60665-94	FLT FXR	1994-98 1994
67659	60782-06	Dyna w/Glide FXST	2006-on 2007-on
67660	60764-06	Dyna (not w/Glide)	2006-on
67662	60553-07	Touring	2007-on

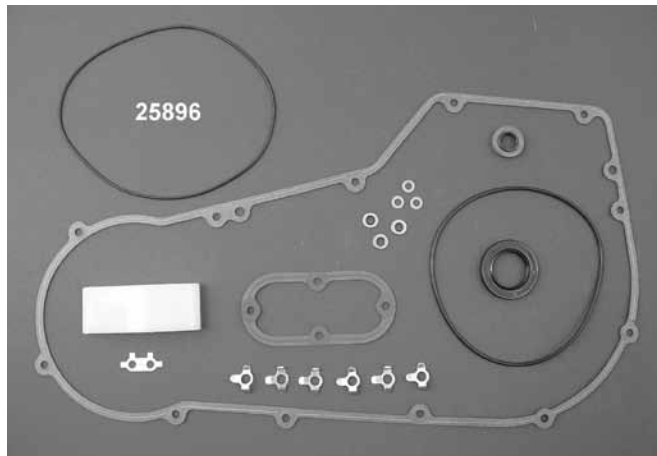

## Preston BT 1985-on Primary Cover Gasket Kit

This kit contains all the necessary parts that are required when making inner primary repairs, primary chain service, clutch hub service, or left side transmission repairs.

25893	1985-93 FLT-FXR
25897	1994-06 FLT-FXR
25878	2007-on FLT
25894	1986-89 FXST
25895	1990-93 FXST
25896	1994-98 FXST-Dyna
25889	1999-06 FXST & 1999-05 Dyna
25887	2006-on FXD
25898	2007-on FXST
25886	2007-on FLT

See Section 17 for a Greater Selection of Gaskets



## FXST/FLST and Dyna Outer Primary 1986-on

Chromed diecast outer primaries manufactured to meet original equipment fitment.

86010	Chromed 1986-88 9 hole (60543-86A)
86018	Chromed 1989-93 (60543-89)
18547	Starter shaft bushing 1989-93 (33446-89)
86027	Chromed 1994 Dyna and Softail (60543-94)
18587	Starter shaft bushing 1994-06 (33446-94)
86038	Chromed Softail 1995-98 (60543-95)
86039	Chromed Softail 1999-06, Dyna 1999-05 (60543-99)

# Outer Primary

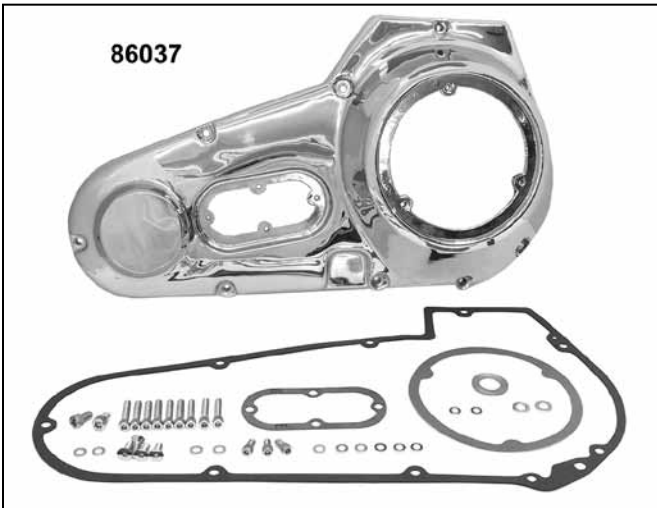

## Chrome FLT & FXR Primary Covers 5 Speeds

Used on all 1985-88 FLT, Classic and 1982-88 FXR's. Cast construction to OEM specifications, supplied with no hardware.

**86007** 60665-85B



## FXE Primary Covers 1982-on 4 Speeds

Add both beauty and strength to your motorcycle with the stronger-than-stock construction found in this reinforced die-cast outer primary cover. Has partially tapped ninth hole for nine hole applications. For 4 speeds.

### PCP Description

- 86037** Chromed 1982-85 FXSB (front belt) with factory rear belt, includes screws, bearing, inspection & derby gaskets (60531-83B)
- 86009** Chromed FX models 9 hole 1983-85 less hardware .350" from gasket hole to bearing surface (small locate hole) (60531-83B)
- 86010** Chrome 9 hole less hardware 1986-88 .540" from gasket hole to bearing surface (large locate hole) (60543-86A)

## Chrome Primary Cover Screw Kits

Acorn	Cap	Allen	Description
<b>8914</b>	<b>8915</b>	<b>8916</b>	BT 1985-99 5-spd (not FXST 89-on)
<b>8917</b>	<b>8918</b>	<b>8919</b>	FXST 1989-06, Evo & TC 1989-06, Dyna 1991-05
<b>9958</b>		<b>9959</b>	Twin Cam 88 FLT 1999-06



## Chain Housing Needle Bearing

Use for starter drive. Replaces #9063. Use on 1965-88 BT, 1967-up XLH.

**15609**



## Chrome Outer Primary Covers FXD, FXST

Fits 2006-on FXD and 2007-on FXST models.

### PCP Application

- 86076** FXD (60764-06)
- 86077** FXST, FXDWG (60782-06)

## Primary Hardware

PCP	OEM	Description
<b>15609</b>	9063	Outer primary bearing 1965-88 (each)
<b>11823</b>	31502-65	Starter shaft washer 1965-88 (5 pack)
<b>23028</b>	50100-70	Kickstand bumper pad (5 pack)

# Outer Primary



**Chrome Outer Primary FXST and Dyna**  
This kit includes all hardware and fits FXST 1999-06, Dyna 1999-05.  
**86039**



**Chrome Primary Kit**  
Kit includes derby, inspection cover, gasket and allen screws. PCP#86063 and 86064 include 5 hole late derby cover.

PCP	Application
<b>86063</b>	1995-06 FXST
<b>86079</b>	2007-on FXST, 2006-on FXDWG
<b>86078</b>	2006-on FXD
<b>86064</b>	1994-06 FLT
<b>86065</b>	1989-93 FLT-FXR
<b>86029</b>	1985-88 FLT-FXR

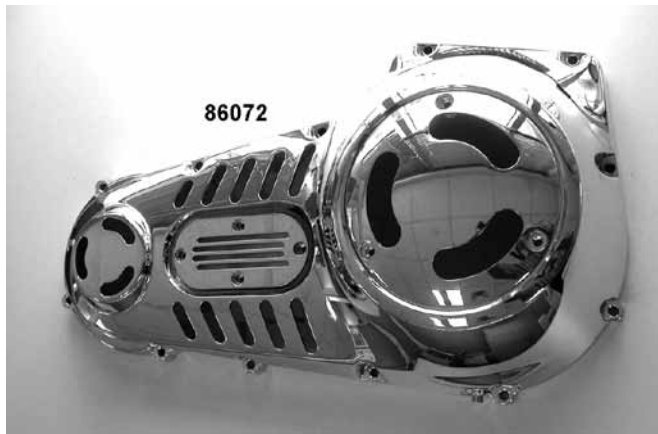

**Chrome Vented Primary Covers**  
Fits FXST & to 2005 FXD models. All parts sold separately.  
**PCP Year**  
**86072** 1994-06  
**86073** 1986-93  
**45721** Derby  
**45722** Oval



**Big Twin Outer Primary Covers**  
Big Twin outer primary covers are from new die cast tooling to replace stock parts. Kits include chrome primary cover, chrome allen screws, outer cover starter bearing and gaskets for derby, inspection and outer cover. All other covers are sold as cover only. Screw kits are sold separately.

PCP	Application
<b>86058</b>	1989-93 FXR, FLT, Chrome (60665-89)
<b>86059</b>	1994-96 FXR, 1994-98 FLT, Chrome (60665-94)
<b>86060</b>	1999-06 FLT, Chrome (60665-99)
<b>86061</b>	1995-98 FXST, FLST, FXD, Polished (60543-95)



**Chrome Primary Allen Screw Kit**  
Fits FXST 1989-06, Dyna 1991-05, and Twin Cam 1999-06.  
**8919**

# Inspection & Derby Covers



## Twin Cam Flame Cover Softtail 1999-06

Feature chrome plated die cast designs for Big Twins.

**45371** Derby cover, 5-Hole



## Flame Derby and Inspection Cover Set

Round chrome derby cover and oval inspection cover feature a bevelled edge and stylish flame design.

**45278** 1999-06 FXST/FXDWG, 1999-05 dyna

**45372** 1965-98 FL & FXST



## 5-Hole Chrome Derby for Twin Cam

Fits FXD 1999-05 and FLT 1999-06.

### PCP Description

**45299** Derby Touring, Softtail 1999-06 and Dyna 1999-05 (60668-99)

**63051** USA made as above

**63041** H-D logo derby (53785-99)

**79549** James TC derby gasket w/silicone on 2 sides (5pk)

**14583** Seal (10 pk)

**45730** Derby Touring/Softtail 2007-on and Dyna 2006-on



## Eagle Sprit Covers

### PCP Application

**45082** Chrome derby cover XL 94-03

**45055** Chrome LTR derby Touring and FXST 1999-06

**6592** Chrome derby cover BT 1970-98

**45210** Gold derby cover BT 1970-98



## Chrome 3 Hole Derby Covers

3 Bolt type for 1970-98 BT. Gasket not included.

### PCP Design

**45719** "Bonehead" Skull

**45720** Cross



## Chrome Billet Outer Primary

Fully CNC machined to fit 1990-06 FXST, FXD models. Cover is designed to make installation/removal of and adjustment of high performance clutch packs easy by removing the derby covers.

**86062**

# Inspection & Derby Covers



**Flying Wheel Derby and Inspection Oval Sets**  
**45374** 1999-06 FXST, FXDWG and 1999-05 Dyna

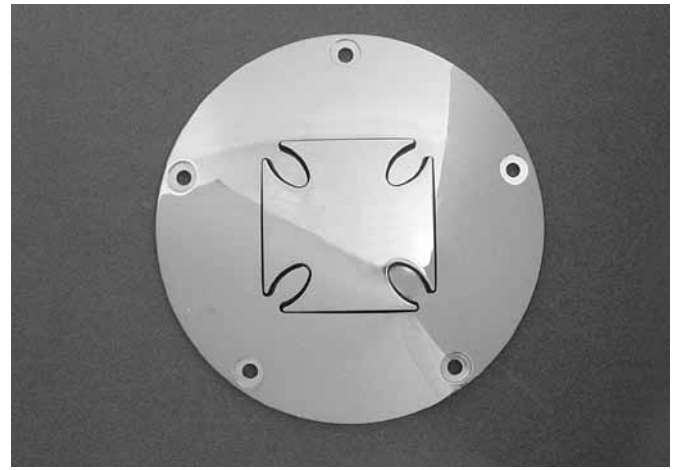

**Billet Iron Cross Derby and Point Covers**  
 Features chrome Billet cover with chrome raised iron cross.  
 Fits Touring and Softail 1999-06.

- 45838** 5 Hole Derby
- 45839** 3 Hole Derby
- 45412** TC88 Points cover
- 45444** 1970-99 Big Twins points cover



**Chrome Billet Flying Wheel Derby Cover For Big Twin**

- 45835** Fits 1999-06 Touring and Softail
- 45527** Fits 1970-06 Inspection oval



**Chrome Billet Oval Inspection Cover**  
**44089** Fits 1965-06 Big Twin and Softail models.



**James New TC Derby Gasket**  
 This gasket is silicone coated on both sides for 1999-06.  
**79549** 5 pack



**Billet Slotted Chrome Oval and Derby Kit**  
 Fits 1970-98 primary covers.  
**59265**

# Inspection & Derby Covers



## "Eagle Spirit" Inspection Covers

Fits FXWG, FXST and FLST 1980-up and most FX 4 speeds with forward controls.

**5059** Chrome

## Chrome Inspection Covers

Flat steel covers for Big Twins with forward controls.

### PCP Fits

- 1153** FXST, FXWG models 1980-1985 (countersunk holes) (60572-78T)
- 44500** FXST/S, FLST 1986-06 and FXDWG models 1993-05 (flat holes) (60572-86)
- 44505** FXD 1991-05 w/hole (not FXDWG) (60529-90A)



44501



44502

Flat steel inspection covers for Big Twins with through-the-primary shift and/or foot peg mount.

### PCP Fits

- 685** 4 speed FX models 1974-1985 with through-the-primary shifter and foot peg mount (60579-74T)



14070

18591

## FX Inspection Cover Bushing and Seal 1974-85

### PCP Fits

- 14070** Seal. Sold in (5 pk) (60641-74)
- 18591** Bushing (ea) (60593-74)

## Chrome Inspection Covers for 5 Speeds Without Shift Holes

### PCP Application

- 44502** FLT models 1985-06 (60670-85A)

### With Shift Holes

- 44501** FXR models 1985-94 (60667-85A)
- 18592** Early bushing 1982-E84 (ea) (60629-82)
- 18556** Late bushing sleeve L1984-on (34632-84A)



45165



45164



45166

## Flame Covers

Chrome plated diecast designs for BT 1970-on.

### PCP Description

- 45164** Derby cover, 3 hole 1970-98
- 45371** Derby cover, 5 hole 1999-06
- 45165** Points cover 1970-98
- 45523** Points cover 1999-on
- 45166** Inspection cover Softail 1986-on
- 44506** Inspection cover FLT, FXR 5 speed 1985-06
- 45167** 5 speed trans end cover 5 speed 1986-on



44506

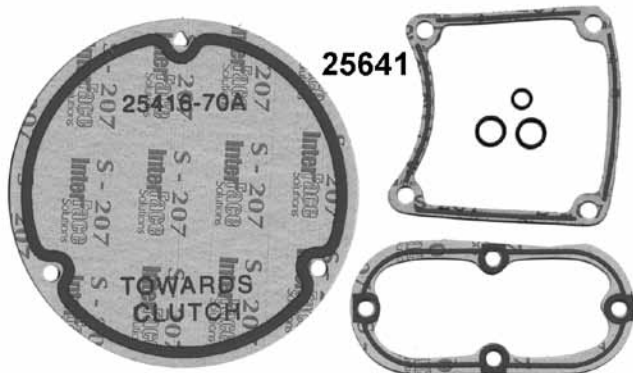

25641

## Primary Derby Gasket Kit

Perfect for use after clutch and primary chain adjustment on BT models 1970-on. Includes gaskets and seals.

### PCP Application

- 25640** 1999-06 5 Hole
- 25641** 1970-98 3 Hole

# Inspection & Derby Covers



**Diecast Chrome Smooth Derby Cover**  
1368 BT 1970-98 (60668-84-B)



59001



59000

## 3-D Derby

Features concealed mounting by use of plate which installs like a Derby. Chrome 3-D spinner cover mounts to stud on plate and is held firmly in place by O-ring. Backing plate may be painted to match colour scheme.

59002

3753



3754



1369



3292



3102



## Finned Primary Cover Accessories

An assortment of accessories for 4-speed Big Twin primary covers as well as all Big Twin point covers. Available in chrome or with a durable black powder coat finish.

Chrome	Black	Fits
1369	3753	Derby cover 1970-98
3292	3754	Inspection with bushing 1974-85
3102		Point cover—top to bottom screw placement



## Chrome Vented Oval and Derby Kit 1970-98

Diamond grill design. Fits 1970-99 4 speed models, features V-Twin design venting for belt drive applications.

45552 Kit

86001 Derby only



## Domed Derby Covers and Inspection Plates

Chrome plated covers with extra non-functional buttonhead Allen screws for that high-tech look.

**PCP Fits**

5486 Domed Points Cover

5487 Derby cover (25414-70) 1970-98

5488 Inspection cover (60572-78)

5489 Inspection cover FX 1974-on w/mid-shift (60579-74)

5491 Inspection cover FXR models 1985-on (60642-85)



45724

## Red Baron Derby Covers

Billet profile construction.

PCP	Type	Holes
45723	Derby	5
45724	Derby	3
45726	Timing	5



59871

## Red Baron Chrome Derby

Die-cast construction. Derby shown installed on primary cover that is sold separately.

59871 5 Hole Touring and Softail 1999-06

59872 3 Hole

# Inspection & Derby Covers



## Topline Chrome Slotted Timer Cover

The deep-dish chrome cover features stainless steel mounting hardware and a slotted design with black-out background.

**63043** 1999-on Twin Cam models (32102-01)

## Topline Chrome Slotted Derby Cover

This deep-dish chrome cover features stainless steel mounting hardware and a slotted design with black-out background that upgrades the appearance of any open primary system.

**63042** 1999-06 TC models except Touring (25345-01)



## Chrome Skull Design Cover

PCP	Type	Application
<b>45482</b>	Points	1970-98 BT
<b>45483</b>	Points	1971-on XL
<b>45416</b>	Points	1999-on TC88
<b>59171</b>	Derby	1970-98 BT
<b>59172</b>	Derby	1999-09 BT



## Chrome Maltese Cross Covers

PCP	Cover	Type
<b>59184</b>	Derby	3 Hole BT
<b>59185</b>	Derby	5 Hole BT TC
<b>59186</b>	Points	2 Hole
<b>59187</b>	Points	5 Hole TC



## Topline Billet Covers BT Evo

PCP	Application
<b>63001</b>	Timing cover BT 1980-98 (32546-94A)
<b>63004</b>	Inspection cover FLHT, FLHR 1985-06 (60628-94)
<b>63005</b>	Inspection cover all FXST, 1980-95 FXWG and FXDWG (60644-94A)



## Chromed Finned Billet Covers (U.S.A.)

U.S.A. made aluminum covers that are polished and chrome plated. Each cover comes with polished stainless steel hardware. These high quality covers are a great match to Preston's **6841** chromed finned EVO rocker covers. Installing these covers adds an extra touch to your bike.

PCP	Description
<b>59011</b>	Inspection cover "oval" 1970-on FX and Dyna w/shifter footpeg hole, seal & bushing (60579-74)
<b>59012</b>	Inspection cover "square" w/o shifter hole, 1985-92 FXR with forward controls
<b>59013</b>	Inspection cover "square" with shifter hole for 1985-92 FXR
<b>59016</b>	Master cylinder lid 1982-on
<b>59018</b>	Swing arm pivot covers for 1982-90 FXR models (47825-81,47826-81) (pair)
<b>59019</b>	Swing arm pivot covers for 1991-92 FXR models (pair)

# FXR-FLT Primary

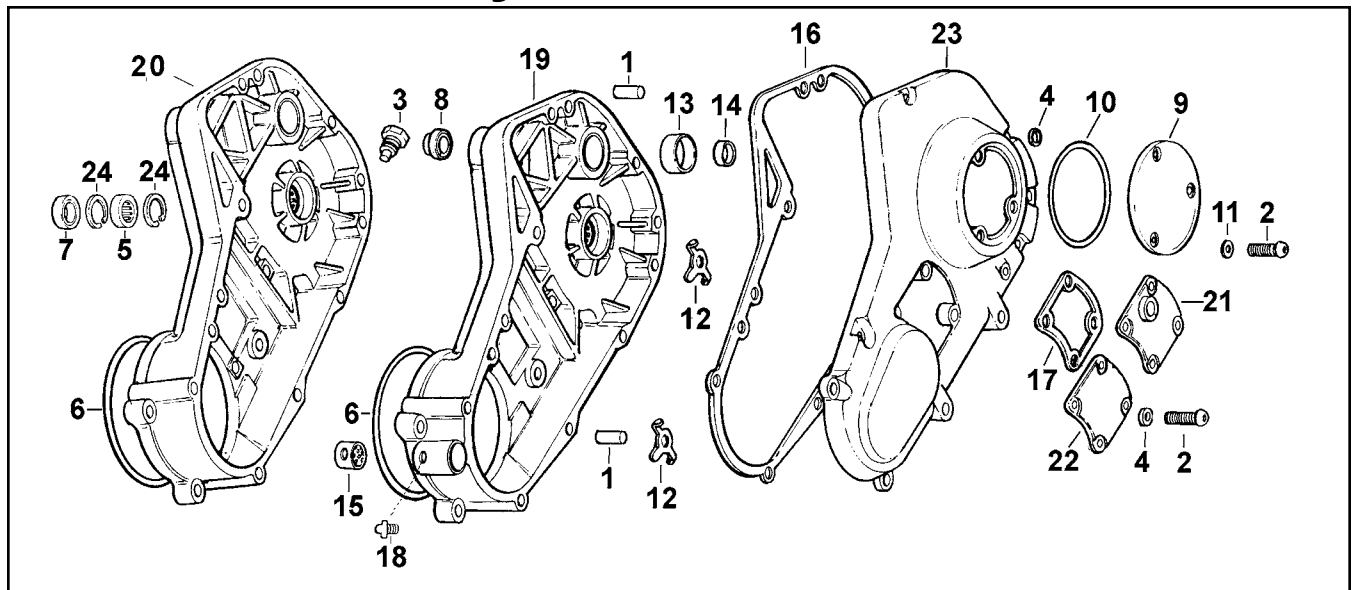

## Primary Housing FLT 1991-06, FXR to 1994

#	PCP	OEM	Description	#	PCP	OEM	Description
1	10190	221	Pin (each)	13	18622	33445-89	Bushing 1989-93
2	24534	923	Screw 1987-93 (10 pk)		18572	33445-94A	Bushing 1994-06
3	10616	722A	Magnetic plug	14	18547	33446-89	Bushing 1989-93
4	12003	6099	Washer to 1993 (10 pk),		18587	33446-94A	Bushing 1994-06
5	15722	9135	Bearing 1985-06	15	18623	33713-85	Bushing, shifter 1985-00
6	14522	11147	Oring, housing cover (10 pk)		18625	42642-00	Bushing, 2001-on
	79033		As above, James 1982-06	16	79330	34901-85	James gasket, cover 1985-93 (5pk)
7	14024	12052	Oil seal (5 pk) 1984-04		79332	34901-94	James gasket 1994-06 (5 pk)
	79082		James as above (5 pk)	17	79339	34906-85A	Gasket, inspection cov. 1985-04 (5)
8	79063	12052A	James oil seal 2006-08 (5 pk)	18	10516	50972-75	Grease fitting (10 pk)
	79085	12053	James oil seal 1989-93 (5 pk)	19	67608	60432-94	As above, '94-00 all FLT not (FLHT)
	14104	12066	Oil seal 1994-06 (5 pk)		67622	60432-01	Black, Touring models 2001-06
	79507		As above, James (5 pk)		67621	60739-01	Chrome, Touring models 2001-06
	79065	12066A	James oil seal 2006-08 95 (5 pk)		67629	60739-07	Chrome, Touring models 2007-on
9	1368	60668-84B	Chrome clutch cover 1970-98	20	86031	60662-90	Inner cover FXR 1989-93
	45299	60668-99A	5 hole chrome cover 1999-06	21	44501	60667-85	Chr/inspection cover FXR 1985-94
10	14537	25416-84A	O-ring, clutch cover 84-92(10 pk)	22	44502	60670-85A	Chrome inspection cov. FLHT 85-06
	14583	25416-99B	Quad O-ring cover 1999-05 (10 pk)		44506		As above with flame design
11	79300	31433-84A	Rubber washer 1984-09 (5 pk)	23	67656	60665-89	Chrome FLT 89-93, FXR's 91-93
12	13716	33318-85	Locking tab 1985-05 (10 pk)		67657	60665-94	Chrome cover 1994-98 (not FLHT)
					67658	60665-99B	Chrome cover all models except FLHT 1999-06
				24	11103	60678-85	Retaining ring (5 pk) 1985-on

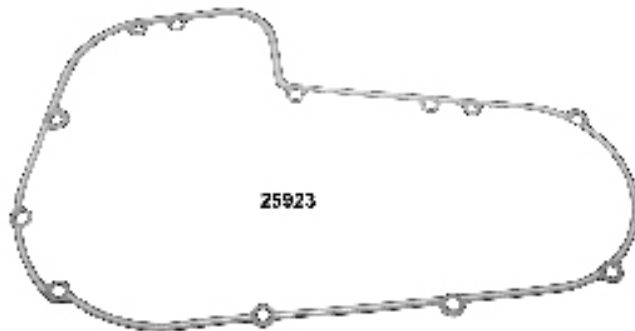

## Primary Gaskets

### FLT-FXR

#### PCP Application

- 14537 Derby o-ring 1984-98 (25416-84A) (10 pk)
- 14583 Derby o-ring 1999-05 (25416-99A) (10 pk)
- 25923\* Primary 1985-93 (34901-85A) (5 pk)
- 25939\* Metal primary 1994-06 (34901-94B) (each)
- 25925\* Inspection FLT 85-00, FXR 85-94 (34906-85D) (10)

\* Note Topline



# Inner Primary

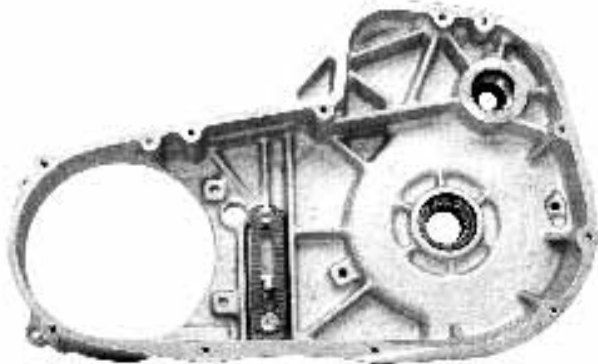
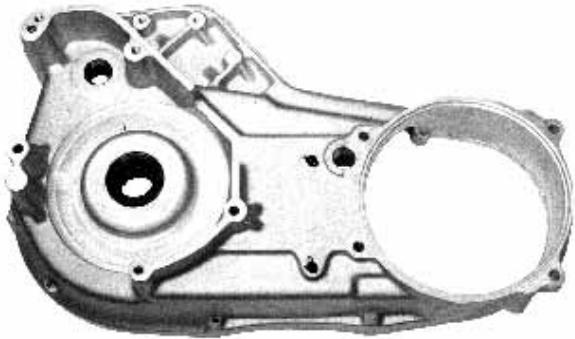

## Revolution Inner Primary Covers

PCP	OEM	Year	Finish	Model
67608	60432-94	1994-00	Black	FLT (not FLHT)
67622	60432-01	2001-06	Black	Touring
67621	60739-01	2001-06	Chrome	Touring
67629	60739-07	2007-on	Chrome	Touring

## Delkron FXR Inner Primary

Aluminum, cast primary features extra material to strengthen original design. Includes main bearing and seal, starter shaft oil seal, starter shaft bushing and the chain adjuster installed.

**86031** Fits FXR 1989-93



## Stepped Inner Primary Bearing Race

Fits 1991-05 BT. Race features an extra step on the inside diameter that acts as a stop on the transmission mainshaft. When the race is pressed on the shaft the step will not allow the race to move inward toward mainshaft seal.

**11905**



## Inner Primary Chrome Stamped Covers

Easily adapt to stock cast inner primary without complicated disassembly.

PCP	Year	Model
3154	1984-E86	FLT, FLHT
3155	L1986-88	FLT, FLHT
45409	1989-99	FLT, FLHT
45435	2000-05	FLT, FLHT
4961	1986-88	FXR
45408	1986-88	FXST, FLST
45410	1989-93	FXST, FLST



# Inner Primary



## Chrome Inner Primary Cover Assemblies

These assemblies include bearings, bushings and seals as required.

PCP	Application
86040	1990-93 FXST-FLST
86041	1994-99 FXST-FLST
67617	1994-06 FXST-FLST (60639-00)



## Chrome FXST Primary Cover Set

Set includes a die cast chrome inner and outer primary cover.

86046	1990-93
86047	1994-99



## Shift Shaft Primary Plug

For use when forward controls are installed on FXR-FXD models to seal the inner primary when eliminating the mid shift. Includes o-rings and hardware.

73519

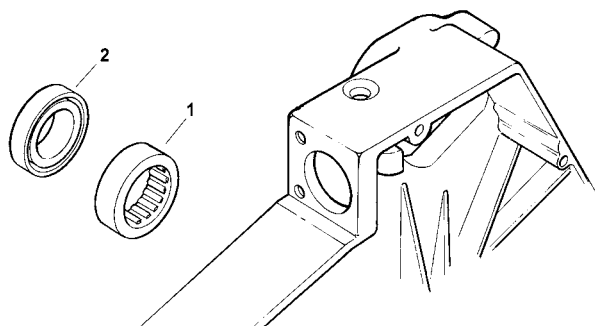

## BT 5 Speed Inner Bearing and Seal

PCP	Application
15722	FXST-FLT L1984-06 (9135 and 12052A)
15739	As above, sealed bearing only
Bearings Only	
15705	FXR-FLT 1980-06, 2 shield (8975)



## Chrome FXST Inner Primary

Fits 1994-99. Hardware sold separately.

PCP	Year
86066	Inner primary
25899	Hardware and gasket kit. 1994-06

# Softail Primary

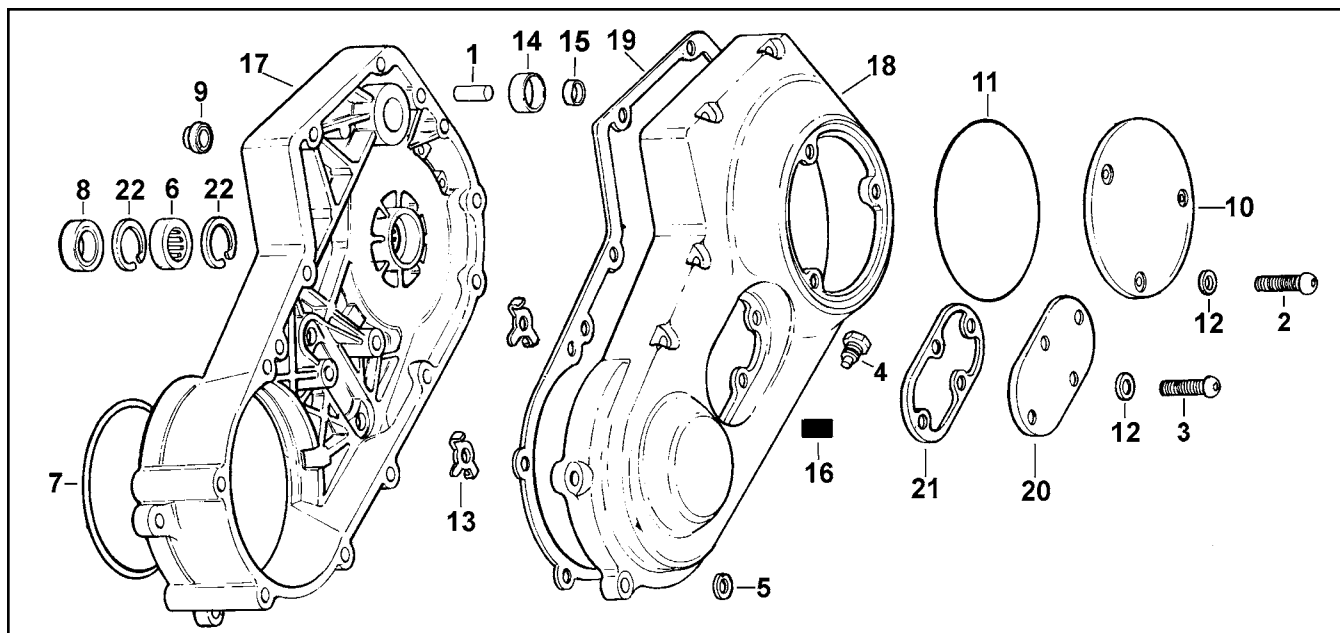

## Primary Housing Softail, Dyna 1991-on

#	PCP	OEM	Description	#	PCP	OEM	Description
1	10113	375	Pin 1991-06 (10pk)	16	23028	50100-70	Bumper k/stand FXST 84-96 (5)
2	24534	923	Derby screw 1987-93 (10 pk)	17	67607	60630-94B	Inner cover b/w FXSTC 1994-06
3	24535	924	Inspection screw 1989-93 (10 pk)		67617	60639-00	Chrome inner cover FXST 94-06
4	10613	739A	Magnetic plug 1991-98		67609	60663-95A	1995-00 Stock FXD
5	12003	6099	Washer 1982-95 (10 pk)		67610	60691-94A	Black 1994-00 FXDL/FXDS
6	15722	9135	Bearing 1985-06		67611	60692-94A	Black 1994-00 FXDWG
	15725	9231	Bearing 2007-*		67612	60724-98A	Black wrinkle 1998-06 FXSTB/I
7	14522	11147	O-ring 1982-05 (10 pk)		67618	60699-99	B/W inner cover FXDX 1999-00
8	14024	12052A	Oil seal (5 pk) 1984-04	18	67651	60543-89	Chr. cov. FXST 89-93, Dyna 92-93
9	14022	12051	Starter oil seal 1984-89 (5 pk)		67652	60543-94	Chrome cover all 1994
	79081	12051	James as above		67653	60543-95	Chrome cover all 95-98 ( not FXD)
	79085	12053	James oil seal 1989-93 (5 pk)		67654	60543-99B	Chrome cover 1999-05 FXDL/X/
	14104	12066	Oil seal 1994-06 (5 pk)	19	79420	60539-89	James gasket .062 w/silicone
	79507		As above, James				1989-93 (5pk)
10	1368	60668-84B	Chrome clutch cover 1970-98		79421	60539-94	As above 1994-04 (5 pk)
	45299	60668-99A	5 hole chrome cover 99-06	20	44500	60572-86	Chrome cover FXST/C,FLSTC,
11	14537	25416-84A	O-ring, clutch cover '84-92 (10 pk)				FXDWG 1986-06
	14583	25416-99A	Quad as above 1999-05 (10 pk)		44505	60529-90A	Chrome cover FXDL/FXD 1991-05
12	79299	31433-84	Nylon washer 1984-98 (20 pk)	21	79430	60567-90C	Gasket 1991-06 (5 pk)
	79300	31433-84A	Rubber washer 1984-09 (5 pk)	22	11103	60678-85	Retaining ring 1985-on (use one
	25295	31433-84A	Bolt washer and o-ring (10 pk)				only for 2007-on models) (5 pk)
13	13716	33318-85	Locking tab 1985-05 (10 pk)				
14	18622	33445-89	Bushing 1989-93				
	18572	33445-94A	As above, 1994-06				
15	18547	33446-89	Bushing 1989-93				
	18587	33446-94A	As above, 1994-06				



## Topline Primary Gaskets - USA

FXST-Dyna

PCP Application

14537	Derby o-ring L1984-92 (25416-84A) (10 pk)
14583	Derby Quad seal 1999-05 (25416-99C) (10 pk)
25928	Primary, alloy w/silicone 1994-06 (60539-94B) (each)
25926	Primary 1981-85 (60538-81E) (5 pk)

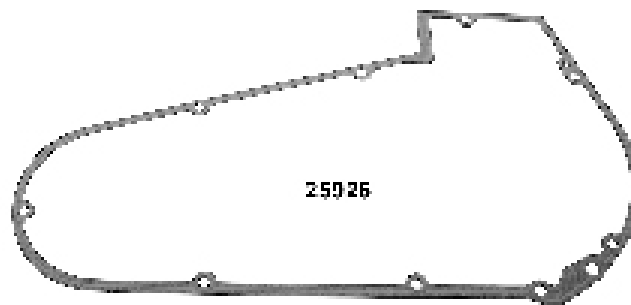

# Inner Primary

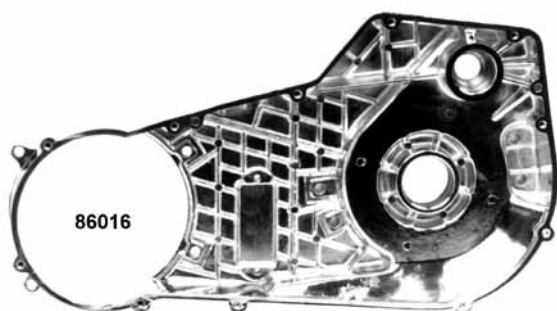

## FXST and FLST Inner Primary Cover

Diecast inner primary cover manufactured to meet original equipment fitment. No hardware included.

- 86032** Chrome 1994-06 (60630-94A)
- 86033** Polished 1994-06 (60630-94A)
- 86016** Chrome 1990-93 (60630-90, & 60441-90)
- 86015** Polished 1990-93 (60630-90)

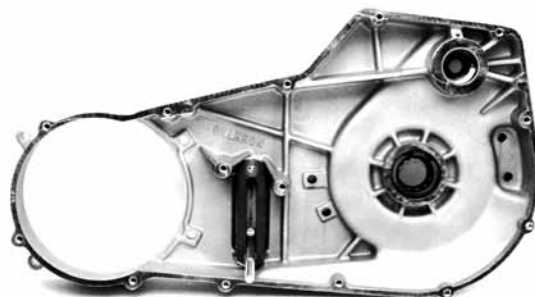

## Delkron FXST Inner Primary 1994-05 )

Features: enhanced engineering, quality aluminum construction, and CNC machining. Cast from 365 T-6 aluminum with reinforcement of all mounting areas and wall thickness. Machined on a CNC horizontal mill for exact locating and tolerances. Primary comes with cast aluminum finish with chain tension anchor plate, main shaft bearing seal, and the starter motor shaft bushing and seal installed.

- 86030** 1994-06 (60630-94)

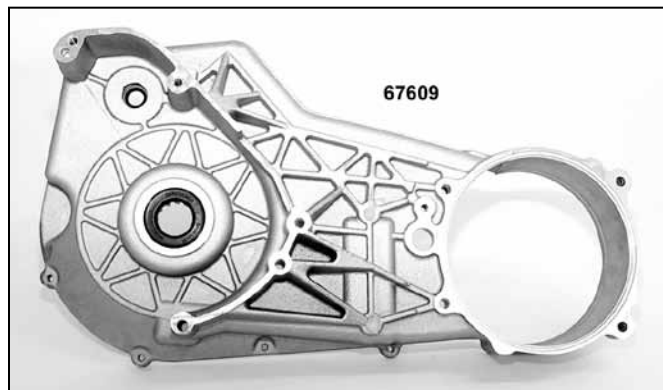
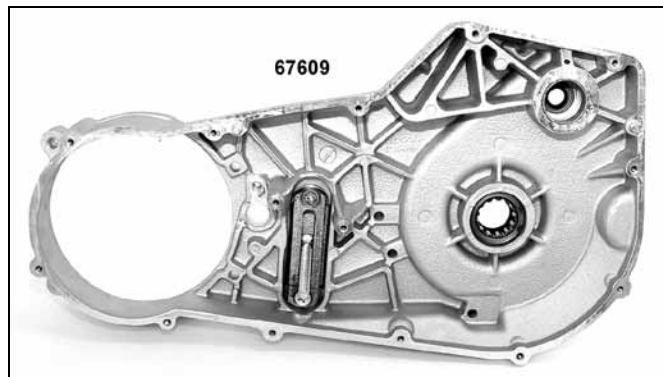
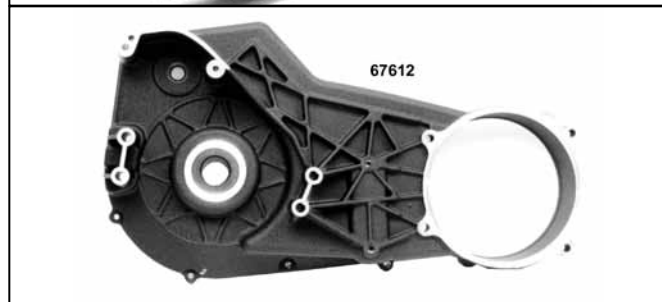
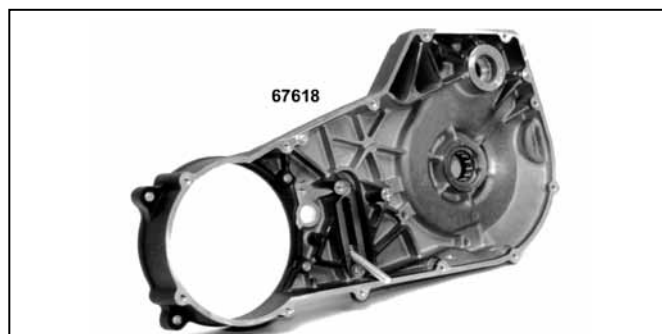
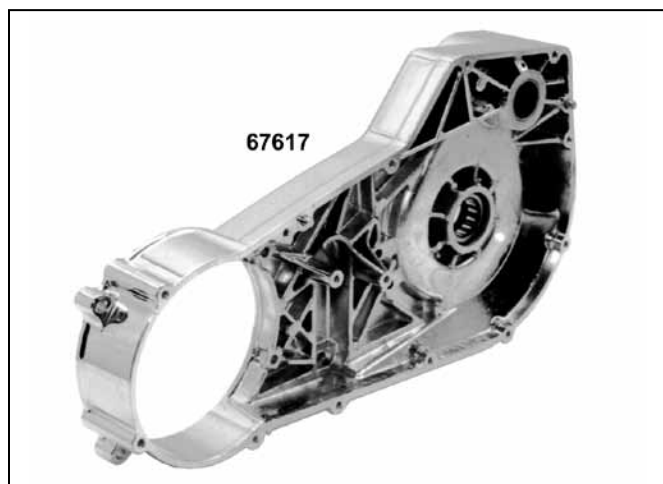

## Revolution Stock Inner Primary Covers (U.S.A.)

PCP	OEM	Year	Finish	Model
<b>67605</b>	60630-86A	1987-88	Stock	FXST
<b>67607</b>	60630-94B	1994-06	Stock	FXST
<b>67612</b>	60724-98	1998-06	B/W	FXST
<b>67617</b>	60639-00	1994-06	Chrome	FXST
<b>67628</b>	60792-06B	2007-on	Chrome	FXST (not FXCW/C)
<b>67609</b>	60663-95A	1995-00	Stock	FXD
<b>67623</b>	60663-01	2001-05	Silver	FXD/I, FXDC/I
<b>67619</b>	60751-01	2001-05	Chrome	Dyna (not WG)
<b>67627</b>	60794-06B	2006-on	Chrome	Dyna (not WG or forward controls)
<b>67610</b>	60691-94A	1994-00	Black	FXDL/CON
<b>67624</b>	60616-01	2001-05	Black	FXDL/I
<b>67618</b>	60699-99	1999-00	B/W	FXDX
<b>67626</b>	60699-01	2001-05	B/W	FXDX/T
<b>67611</b>	60692-94A	1994-00	Black	FXDWG
<b>67625</b>	60617-01	2001-05	Black	FXDWG/I
<b>67620</b>	60747-01	2001-05	Chrome	FXDWG/I
<b>67628</b>	60792-06B	2006-on	Chrome	FXDWG/I
		2007-on	Chrome	FXST
<b>67621</b>	60739-01	2001-06	Chrome	Touring
<b>67630</b>	60815-08	2008-on	Chrome	FXCW/C, FXSTSSE3

# Inner Primary



## T/L Chrome Inner Primary Cover 2001-on

Use this chrome cover for Touring models to provide a beautiful finish. This cover includes preinstalled bearings, dowel pins and seals.

- 67621** 2001-06 Touring (60739-01)
- 67629** 2007-on Touring (requires separate purchase of gasket 34901-07 and o-ring 27444-00Y) (60739-07)

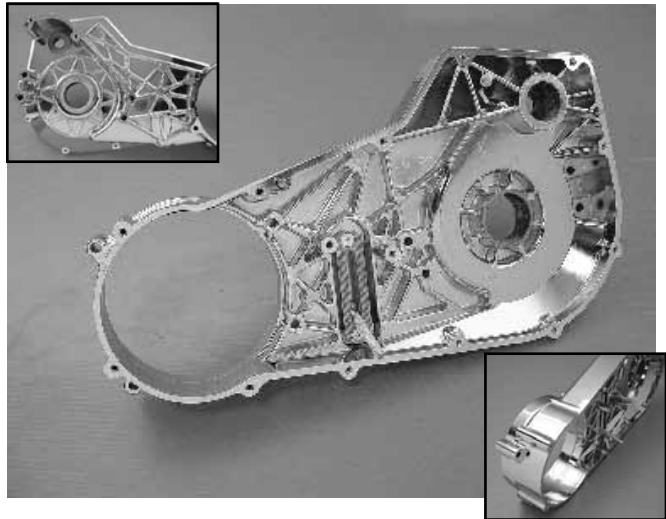

## V-Twin Offset Inner Primary Covers

For 1994-2003 Softail feature chrome finish with reinforcing webs for added strength. Available in offsets for fat tire and wide frame applications. Use 1994-2003 primary components, sold separately.

- 86048** .250 Offset
- 86049** .500 Offset
- 86050** .750 Offset
- 86051** 1.00 Offset
- 86052** 1.25 Offset
- 86053** 1.50 Offset

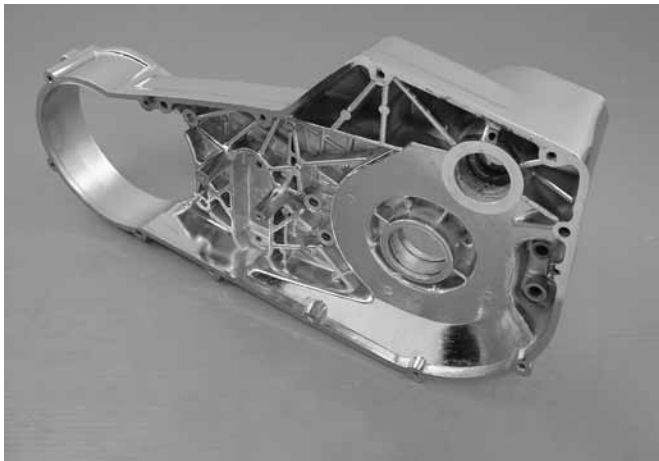
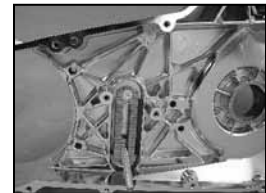

## FLST-FXST Heavy Duty Inner Primary Cover

Features waffle reinforced design by ET Technology.

- 86054** 1990-93, Chrome finish
- 86055** 1990-93, Polish finish
- 86056** 1994-06, Chrome finish
- 86057** 1994-06, Polish finish

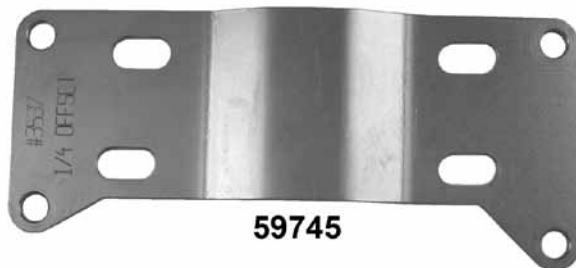

## Offset Transmission Plates

Fits 5 or 6 speed FXST transmissions.

- | PCP   | Offset |
|-------|--------|
| 59745 | 1/4"   |

## Primary Spacers

- | PCP   | Size        |
|-------|-------------|
| 76456 | 1/4" spacer |
| 76457 | 1/2" spacer |
| 76458 | 3/4" spacer |
| 76459 | 1" spacer   |
| 76500 | 1.250"      |
| 76501 | 1.500"      |
| 76502 | 1.750"      |
| 76503 | 2.000"      |

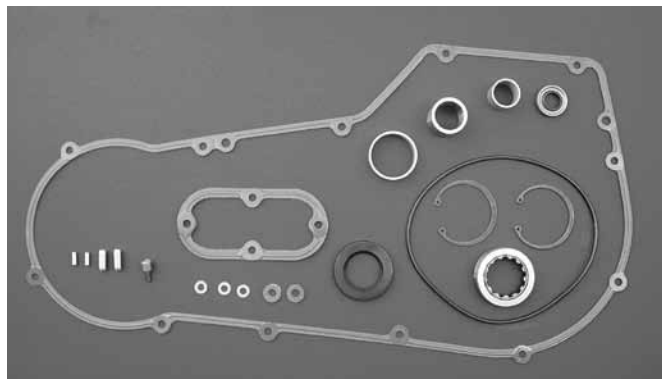

## FXST Inner Primary Hardware and Gasket Set

Includes all parts shown including bearing and inner sleeve.

- 25899** 1994-06
- 25877** 1990-93
- 25876** 1986-89
- 25898** 2007-on

# Inner Primary



## Inner Primary Bearing Kit

Fits L1985-on BT includes bearing, seal, 2 snap rings, and 1 inner race.

PCP	Year	Type
15950	1985-93	Complete
15951	1994-06	Complete
15763	1985-06	Bearing and sleeve kit
11522	1985-06	Race only (34091-85)



## BT Inner Primary Bearing 1985-on

Bearing supports transmission mainshaft at inner primary area. Available as an OEM "floating style" roller bearing type which requires the purchase of an inner sleeve, or as a double sealed ball bearing style which does not require a sleeve.

PCP	Application
15722	Stock roller bearing with seal 1985-06 (9135)
11522	Sleeve for above (34091-85)
15739	Sealed ball bearing
15725	Stock roller bearing 2007-on (9231)



## Inner Primary Mounting Kit

Complete hardware kits properly mount inner primary.

PCP	Application
9869	FL, FX 1980-85
9904	FLT, FXR 1986-2000
9870	Softtail 1986-93, Dyna 1991-93
9873	Softtail 1994-99, Dyna 1994-98
72294	Softtail 2000-06, FLT 2001-06, Dyna 1999-05

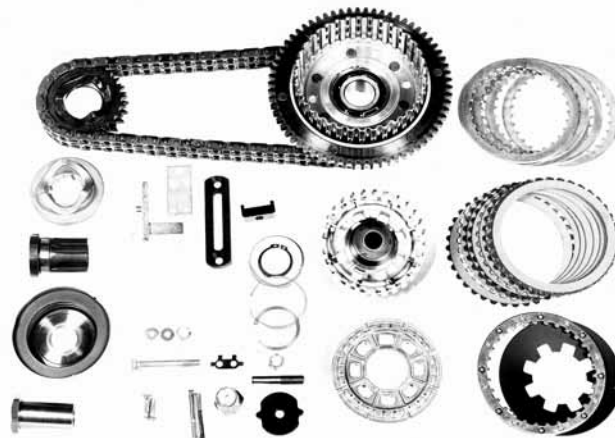

## Primary Chain Drive Systems for BT

Kit includes 82 link or 76 link Diamond primary chain, chain shoe adjuster assembly, clutch drum basket with starter ring gear and steel & fiber clutch plates with pressure plate assembly. Correct front compensator sprocket assembly includes all parts necessary for installation, including sprocket nut. 5 Speed Big Twin Softtail models and all pre 1985 FLH-FX 4 speeds require 82 link primary chains, 1980-on FLT-FXR 5 speeds require 76 link primary chains.

82 Links	76 Links	Year
53087	53091	1998-06
53086	53090	1994-97
53085	53089	1991-93
53083	53088	1985-90



## BT Main Drive Gear Oil Seal and Spacer Kit

Oil seal and spacer fit BT 5 speeds and feature triple lip seal and coated sprocket spacer. The coating provides superior surface lubricity and increased corrosion resistance.

15952



## Inner Primary Repair Gasket Kit

Includes gasket to replace o-ring seal when the lip of the motor is partially or entirely broken off. To avoid machining and welding, grind the partially broken lip smooth and install the gasket. Special lock and bolts included.

PCP	Application
25157	1970-85 FX, FL
25612	1990-05 FX, FL
25617	2006-on FXD with metal gasket (34934-06)

# Sportster Primary

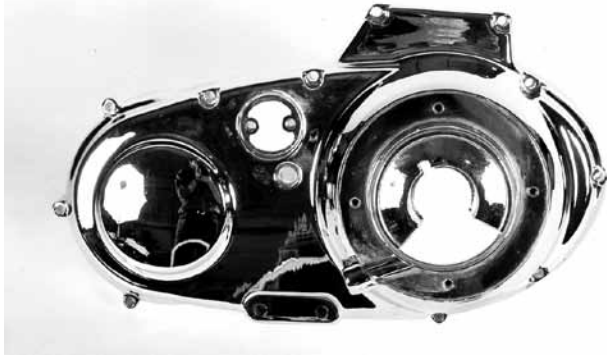

**86024** T/L Chrome 1994-03 (25460-94)  
**86026** Preston as above



**6589** Chrome 883-1200 1986-87 (25430-86)  
**86020** Chrome 883-1200 1988-90 (25430-88)



**86023** Chrome 1991-93 (25430-89)



**Sportster Chrome Inspection Cover 1986-90**  
 For clutch and chain on primary cover for 1986-90.

PCP	Style	Application
<b>44084</b>	Stock	1986-90 (pair)
<b>44085</b>	Hex	1986-90 (pair)
<b>14519</b>	O-ring	L1978-90 (11139)



## XL Chrome Derby and Inspection Covers

To fit 1994-03 models

- 45022** Chain inspection (34761-94)
- 14556** Inspection O-ring (11188) (10)
- 45023** Derby cover (25399-95T)
- 45837** Derby cover 2004-on (25386-04)
- 45082** Derby cover Eagle Spirit
- 45098** Derby cover gold Eagle spirit
- 44074** Derby cover skull
- 14581** Quad O-ring for derby (25463-94) (5)



**5367**

## Primary Chrome Filler Cap & Clutch Hole Cap

Custom chrome plated steel caps have a 15/16 hex to facilitate installation and removal with a standard wrench.

- 5367** Adjuster clutch hole & filler XL 1985-90 (2 needed)
- 79029** O-ring L1978-90 (11139)



## XL Inspection Cover Set 1991-93

For clutch and chain on primary cover. Chromed set.

- 24033** 34742-90, 34745-90

# Sportster Primary



45847



45848

## Customizer Dress Set

Features brilliant chrome covers to fit over original aluminum covers. Covers are formed to mirror the contour for a skin tight fit. Order derby and points cover separately.

PCP	Fits
45847	1991-03
45848	2004-07



## Primary Cap Installation Tool

Use to prevent damage to primary caps on 1971-90 XL  
5800



## Chain Housing Needle Bearing

Use for starter drive. Replaces #9063. Use on 1965-88, BT, 1967-up XLH.  
15609



90155

## Chrome Customizer Dress-Up Kit XL 1986-90

Kit includes chrome primary cover with inspection covers, cam, rocker box, master cylinder, and sprocket covers. PCP #90155 also includes a chrome brake pedal and chrome shift lever to add an extra special touch to your bike. Installation hardware is included.

90155 Complete kit with brake and shift pedals

90156 Kit without brake or shift pedal

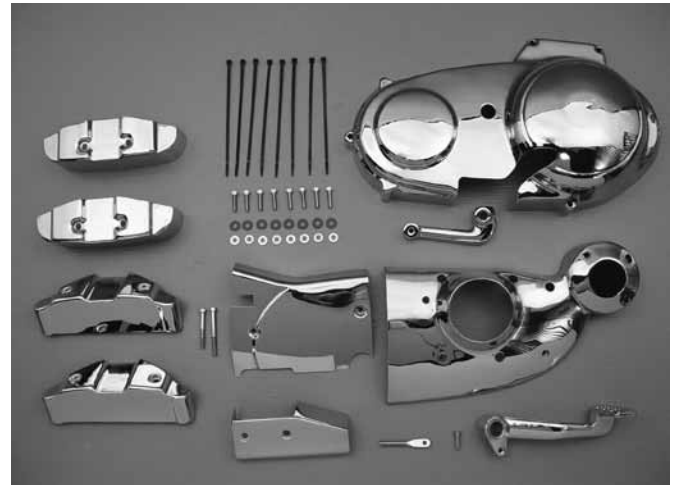

## Chrome Customizer Dress-Up Kit XL 1991-on

Chrome kit includes primary, cam, rocker box, master cylinder, and sprocket covers. Kit can also be purchased with a chrome brake pedal and shift lever to complete the look.

90104 Complete kit with brake and shift pedals 1991-03

90157 Kit without brake or shift pedal 1991-03

90274 Kit without brake or shift pedal 2004-on



90104

# Sportster Primary

90109

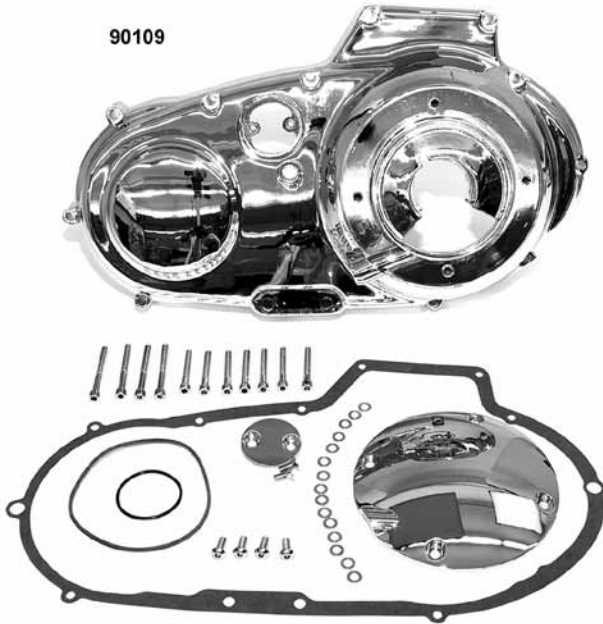

90106

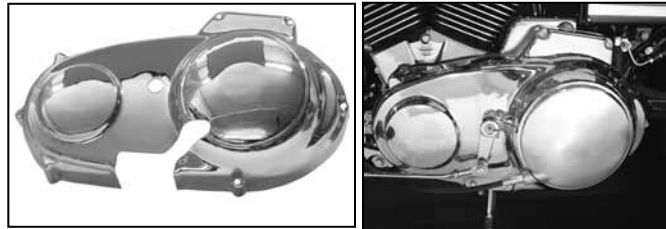
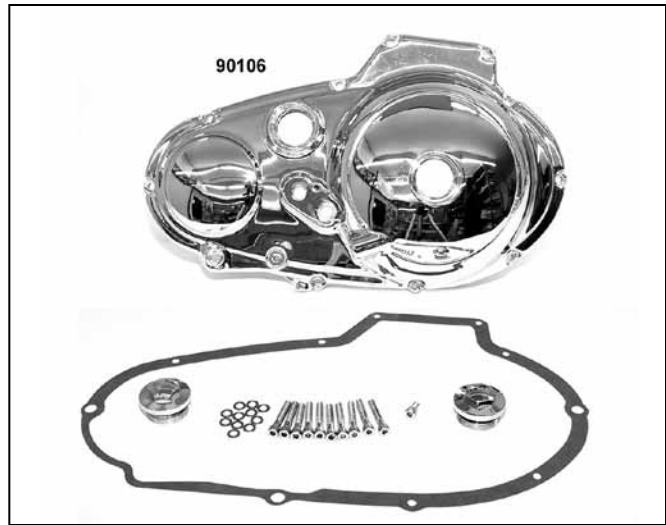

## Chrome XL Primary Kits

Kits include chrome cover, chrome allen screw set, inspection covers and gasket/seals as required.

PCP	Application
90106	1986-90
90108	1991-93 (25430-89)
90109	1994-03 (25461-94)
67647	2004-05 (25461-04)

## Chrome XL Primary Cover Trim 1991-on

Chrome trim completely covers aluminum primary clutch cover and is secured by 5 existing screws. 1994-03 type available as cover with choice of an open derby. PCP#45849 (open derby) requires the reinstallation of clutch cable if reinstalling derby cover. PCP# 45840 includes separate derby and inspection cover. Installation does not require removal of existing cover.

45803	1991-03
45849	1994-03
45840	2004-05



## Colony XL Primary Screw Sets

### Chrome Allen Type Screws

9749	XL 1986-90
9767	XL 1991-93
9769	XL 1994-03



### Chrome Acorn Type Screws

5505	XL 1986-90
9768	XL 1991-93
9770	XL 1994-03



## XL Chrome Primary Cover 1994-03

67646 25461-94

# Sportster Primary

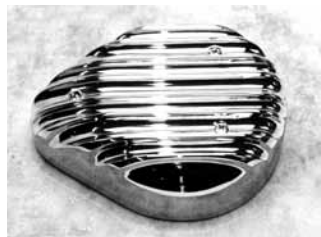

67644



45140



## T/L Chrome XL Primary Chain Cover Kit

Chrome cover kit includes primary chain cover, derby cover and inspection cover. Kit also includes required gaskets and seals. This kit is stock on 2004-on XL 1200C models and is designed for 2004-on XL models.

- 67647** Complete kit 2004-05 (25461-04)
- 67644** Chrome primary cover only 2004-05 (25460-04)
- 61208** Chrome inspection cover only 2004-08 (34761-04)
- 64283** Chrome derby cover only 2004-on (34760-04)

## 2004-on Chrome Derby Cover

PCP	Style
45140	Eagle Spirit
45141	Smooth
45142	Flame
45143	Maltese
44117	Inspection cover



44117



86068

## Chrome Outer Primary Covers 2004-05

Available as chrome cover only or as a kit which includes chrome cover, chrome allen screw set, inspection covers and gasket. Replaces 25460-04 on 2004-05 models.

PCP	Item
86067	Cover only 2004-05 (25460-04)
86069	Cover only 2004-05
86068	Kit 2004-05
86070	Cover only 2006-on
86071	Kit 2006-on

# Sportster Primary

79727

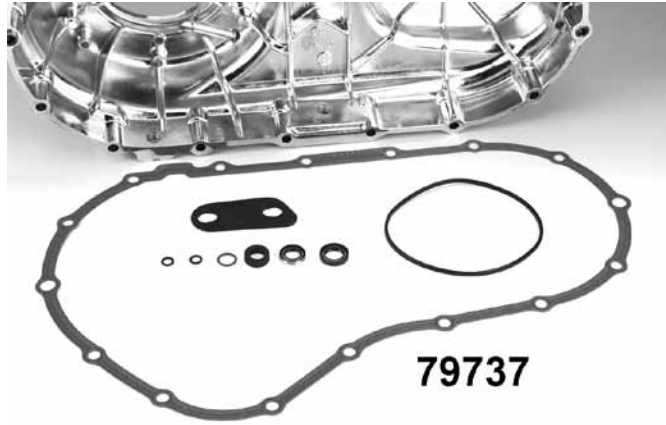
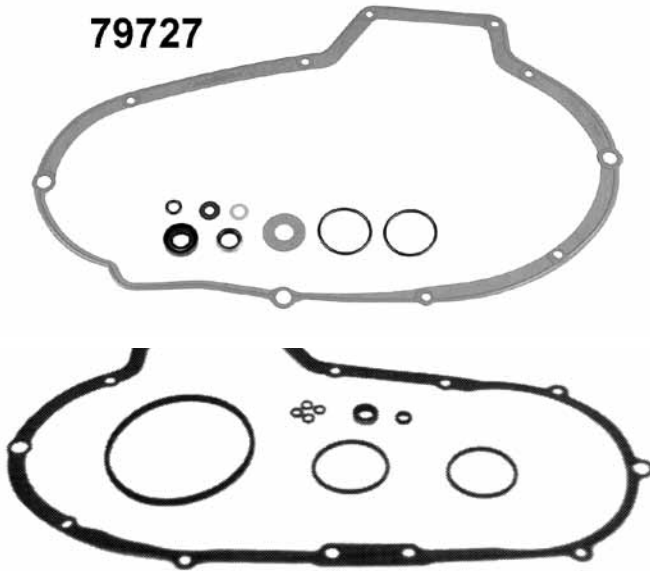

79737

## James XL 2004-on Primary Gaskets

PCP	OEM	Description	U/M
79736	34955-04-F	Primary cover, foamet	Each
79737	34955-04-K	Primary cover and seal kit	Kit

## James Sportster Chain Cover Gasket Kit

PCP	Description
79727	1977-90 (34955-75-K)
79728	1977-90 w/silicone (34955-75-X)
79729	1991-03 883/1200 Gasket and seal set (34955-89-K)
79096	1994-03 O-ring for clutch cover (10 pack) (25463-94)
79354	1991-03 with silicone

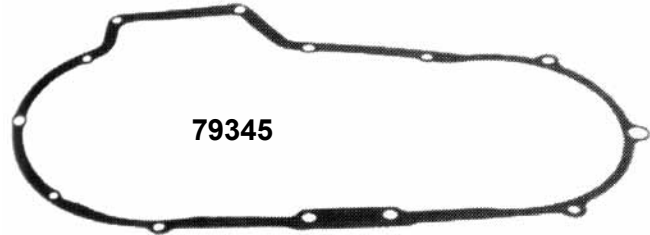

79345

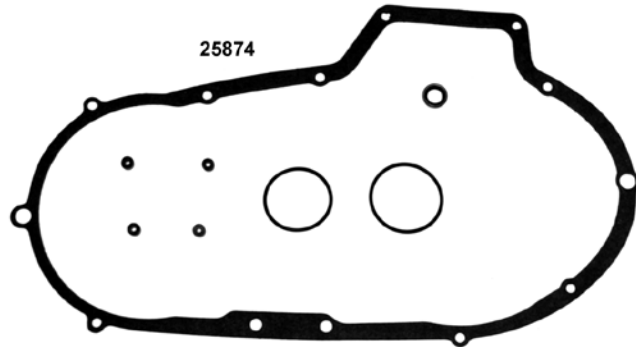

25874

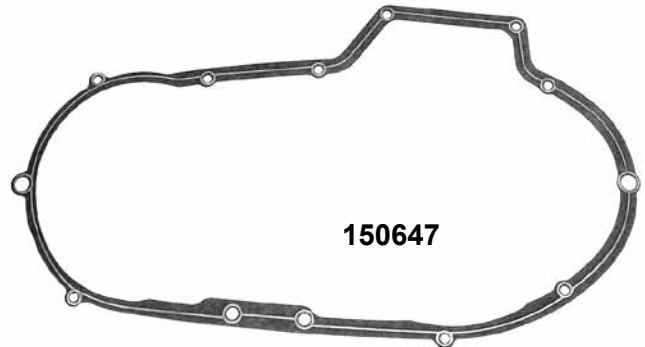

150647

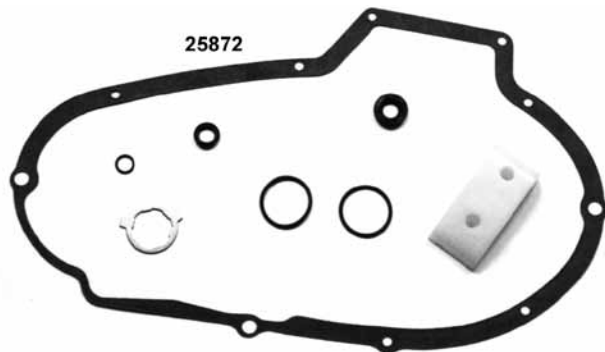

25872

## Sportster Primary Gasket

James	PCP	Application
79344	-	.030 1977-90 (34955-75) (10 PK)
79728	-	1977-90 w/silicone (34955-75-X)
-	25300	1991-03 (5 pk)
79345	-	.030 1991-03 (10 pack)
-	150647	G/B .060 as above w/silicone (5 pack)
79418	-	.031 w/silicone 2004-09 (34955-04) (5 pk)

## Sportster Primary Kit

Includes gaskets and small parts.

PCP	Fits
25872	1980-89 all models
25873	1990 all models
25874	1991-03 all models

# Sprockets



43618

## Solid Motor Sprocket Conversion Kit

The conversion kit replaces the compensator unit and sprocket. Includes nut.

PCP	Description	Teeth
43618	Dyna 1990-on	25



## BDL 1/2" & 1" Offset 25 Tooth Front Sprocket

Sprocket fits FXST 1991-on

76180	1/2"
76417	1"

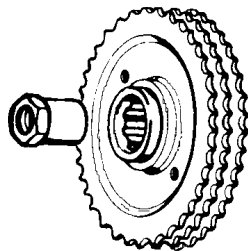

## XLCH Motor Sprocket

PCP	Description
43614	34T sprocket 1977-90 (40235-74)
43615	35T sprocket 1991-03 (40235-89)



**Sprocket Spacer XL**  
1989-01  
11845 40240-89



59628

59630

## BT Offset Motor Sprockets

24T	25T	Application
59628	59632	1/2" Offset
59629	59633	3/4" Offset
59630	59634	1"
59631	59635	1-1/4" Offset



12569



12568



12612

## Motor Sprocket Nuts

PCP	Application (Each)
12568	XL 1970-88 (40387-70)
12611	XL 1989-92 (7652)
11845	XLH 1989-01 Spacer (40240-89)
12569	BT 1970-90 (40392-70)
12612	BT 1991-06 (40392-91)
24001	BT 2007-* (3368 & 6445)



## Motor Sprocket Nut Lock Plate for XL 1967-90

Plate is held in place by 2 hex bolts which are threaded into the stock non-compensating sprocket. Constructed of aluminum.

12610



## 1970-on BT Compensator Engine Sprockets

PCP	Teeth	Application
29080	24	1985-93 FXR, FLT, 1991-93 FXST (40269-85A)
29076	24	1985-90 FXST (40275-83A)
29093	25	1994-06 all BT (40308-94)
21741	21	2002-on BT
29167	34	2007-on BT (40320-06)

# Sprockets



5085

## USA Trans Sprockets

USA made transmission sprockets for all Sportster and Big Twin models from 1936-on. These sprockets are fully hardened for maximum service and performance.

### For Big Twin models 1980-85 (With 4-Speed Transmission)

PCP	Tooth
5085	22 (33338-83)
5086	23 (33337-83)
5087	24
1281	Sprocket Spacer (35079-80)



## BT Sprocket Nut Lock Screw 1980-90

Replaces 857A with nylon patch.

24556 10 Pack



5095



5957

## Sportster Models L1984-90

PCP	Teeth
5095	21 (35208-84)
5096	22
5097	23

## Sportster Models 1991-92

PCP	Teeth
5957	21 (37709-89)
5958	22
5959	23



2489



1281

## BT Transmission Sprockets

High quality imported transmission sprockets, a lower cost alternative to our line of USA made transmission sprockets.

### For Big Twin Models 1980-85 (With 4-Speed Transmission)

PCP	Teeth
2489	23 (33337-83)
2490	24
2491	25
1281	Sprocket spacer (35079-80)



4539



21828

## Transmission Sprockets Sportster

L1984-90	1991-on	Teeth
4539	21828	21 (35208-84)
4540	21829	22
5965	21830	23
5966	-	24



## Sportster Offset Sprockets (1/4" offset)

Fits XL models which allows the use of a 150 series tire. Order rear sprocket spacer separately.

### 4 Speed 1984-90

PCP	Teeth
43622	19T
43623	20T
43624	21T
43625	22T

### 5 speed 1991-05

43626	19T
43627	20T
11855	.200 Spacer

# Rear Sprockets



## Offset Sprocket Kit for Softail® and FXR's

This offset transmission sprocket permits the installation of 'extra-wide' rear tires or final drive ratio changes (belt to chain) drive on Softail® and FXR's. This kit moves the rear chain as far away from the tire as possible, and permits the use of wide 150 series tires. This kit fits 1986-on Softail® models when used with 1973-84 4-speed rear sprockets, and also fits FXR's 1985-94 when used with FXR rear sprockets. The stock final drive ratio on 5-speed models is 2.1875. This installation with a 51-tooth rear sprocket will change the ratio to 2.125, and with a 48-tooth rear sprocket it will be to 2.000 which is for stroker models.

PCP	Description
43600*	21T drive sprocket
43601*	22T drive sprocket
43602*	23T drive sprocket
43603*	24T drive sprocket
11855	Spacer (40932-81)
2543	48T rear FXR sprocket
3281	51T rear FXR sprocket
526	48T rear FXST sprocket
525	51T rear FXST sprocket

**\*Note:** To use on 1994-99 models, drive sprocket spacer and seal must be changed to pre 1994 type. Seal #14021 (OEM 12050) and spacer #11538 (OEM 33334-85).



## BT 1/4" Offset Rear Sprocket & Spacer Kit

This kit mounts wider rear tires on Big Twin 1973-85 4 speeds. Kit includes special 1/4" offset transmission sprocket, rear sprocket spacer plate and mounting hardware.

PCP	Teeth
43608	22T
43609	23T
43610	24T

**Note:** Kit is designed to ease the problems encountered on some Custom Applications. 1979-85 FX models will require modifications, including changeover to a Prestolite starter.



## Chrome-Plated Rear Sprockets with Cutouts

Slotted chrome rear wheel sprockets match the front brake rotors used on all 1984-on. For Big Twin 4 speeds 1973-85  
**43503** 51 tooth  
**43505** 48 tooth for Sportsters 1986-92

## Chrome-Plated Solid Rear Sprockets

"Solid" chrome plated rear wheel sprockets. Fits all 4-speed Big Twins 1973-85  
**43500** 51 tooth  
**43502** 48 tooth for Sportsters 1986-92

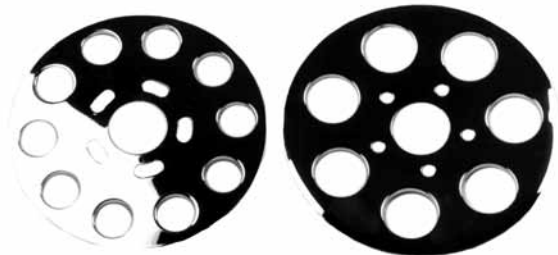

## Chrome Rear Chain Sprocket Covers

Sprocket covers for the stock rear sprockets on many Sportster® and Big Twin models 1973-92. These steel covers are chrome-plated and install over the stock-plated OEM rear sprockets. Use your stock mounting hardware or Colony custom kits.

PCP	Fits
45801	Big Twin 4 speeds 1973-85 & Sportster 1979-81 51T
45800	Sportster 1986-92 with 48T rear sprocket

**Note:** The covers with holes listed above will ONLY fit Harley-Davidson® sprockets, and will require rotating them to the sprocket to get all of the holes to line up.



## Chrome Plated Rear Sprocket Hardware Kit

Includes Flat Head Allen screws, locknuts and companion countersunk washers.

PCP	Application
9856	FL, FX, XL w. chain drive spoke rear (41197-73)
9857	FL, FX 1973-on, XL 1973-91w. cast rear wheel including belt drive (3769). Locknuts not included.
9858	FXWG-FXRS 1985-on with belt drive spoke rear wheel (4736)

# Rear Sprockets



## Rear Disc Brake Sprockets

Various sizes are available for Big Twins 1973-on and Sportster's 1979-92. Plain or chrome-plated.

### Plain

PCP	OEM	Tooth	Dished
524		48	"
3542		49	"
523	41470-78T	51	"

### Chrome

526		48	"
2483		49	"
525	41470-78T	51	"

## Chrome Sprockets for FXR Models 1982-85

FXR models (except FXRT, FXRP) with rear chain drive.

PCP	OEM	Tooth	Dished
3549		46	"
5967		47	"
2543	40954-81C	48	"
3281	40954-83	51	"

## Chrome Sprockets for Sportster's 1982-85

PCP	OEM	Tooth	Flat
3761	41470-82T	48	"
1235	41464-81	51	"

## Chrome Sprockets for Sportster's 1986-92

PCP	OEM	Tooth	Flat
5997	41493-90T	47	"
5998	41470-86	48	"
5999	41492-90T	49	"
21827	41464-86	51	"



## Sprocket and Disc Spacers

Spacers provide offset when required.

PCP	OEM	Description	Thickness
3376	41814-76	Disc only 1976-81	1/16"
11855	40932-81	Both 1981-on	.200
11856	Alloy	Both 1973-on	1/4"
11857	Alloy	Both 1973-on	5/16"
11858	Alloy	Both 1973-on	3/8"
11859	Alloy	Both 1973-on	1/2"

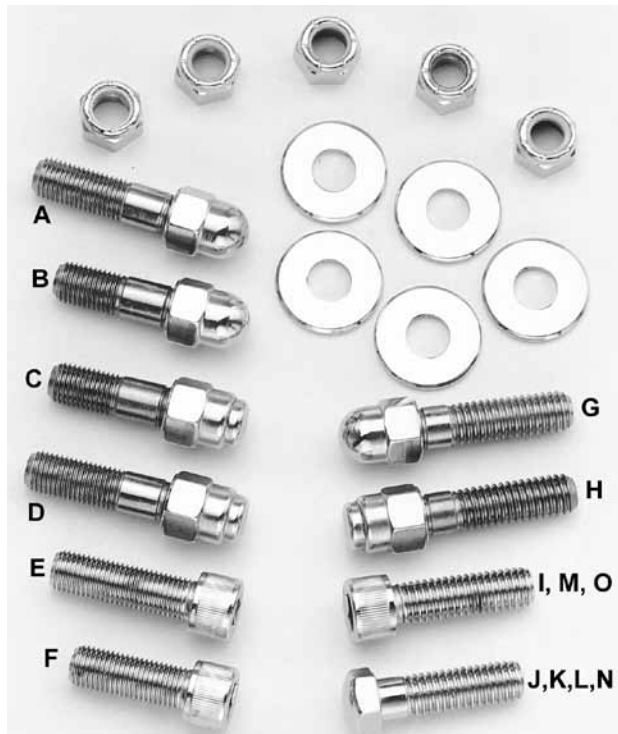

## Colony Chrome Rear Sprocket Hardware Kits

### Sprocket Bolt and Nut Kits

1985-92 BT with belt drive spoke rear wheel (4726)

4363	A	Acorn Style
4366	D	Cap Style
4367	E	Allen Style (7/16-20 x 1-1/2)
72275	E	12 Point (7/16-20 x 1-1/2)

1973-on BT & XL w/chain drive spoke rear wheel (41197-73)

4364	B	Acorn style
4365	C	Cap style
4368	F	Allen style (7/16-20 x 1-1/4)
72276	F	12 Point (7/16-20 x 1-1/4)
9609	J	Domed Hex style

### Sprocket Bolt and Washer Kits

1973-92 BT and 1979-90 XL with cast rear wheel including belt drive and 1993-98 BT except 1997-98 Softail with spoke rear wheel. OEM# 3769, 3771.

4369	G	Acorn style
4370	H	Cap style
4371	I	Allen style (7/16x14 x 1-1/2)
72277	I	12 Point (7/16x14 x 1-1/2)
9608	K	Domed Hex style (7/16-14 x 1-1/2)

1993-96 BT, 1997-98 Dyna and FLT, 1991-99 XL with cast rear wheel and 1997-99 Softail, 1999 Dyna, 1999-on FLT, 2000-on XL with spoke or cast rear wheel

72053	L	Domed Hex style
-------	---	-----------------

1993-96 all BT, 1997-98 Dyna and FLT with cast rear wheel and 1997-99 Softail, 1999 Dyna, 1999-on FLT with spoke or cast rear wheel. OEM# 3730A, 3899.

72054	M	Allen style, polished
-------	---	-----------------------

2000-on Softail and 2000-05 Dyna with spoke or cast rear wheel. OEM # 3737. 7/16-14 x 2-1/4.

72051	N	Domed Hex style
72052	O	Polished Allen style

2006-on Dyna with spoke or cast rear wheel. OEM 3873.

72340	P	Allen style (7/16-14 x 2-1/2)
-------	---	-------------------------------

# Sprockets



59459



21776

## Chrome 5-Spoke Sprockets

Offset models offer a 9.8mm offset.

1986-99		2000-on	
Offset	Teeth	Offset	Teeth
59459	48	21775	48
59460	51	21776	51



59486



59490

## Offset Transmission Sprockets 1994-03

For BT 1994-03 & L1991-on XL's with chain drive conversion.

### Offset Counter Shaft Sprocket

.500"	.750"	.810"	.900"	Teeth
59485	43600	-	-	21
59486	43601	59489	-	22
59487	43602	59490	21738	23
59488	43603	59491	21739	24



## Chrome Lazer Style Sprockets

Sprockets have a 13.8mm offset and feature a milled centre design. Sprockets fit FX 1973-on and FXST chain drive models.

PCP	Teeth
59233	48T
59234	49T
59235	51T



73560



73572



73573

## Sprocket Shaft Extensions

### PCP Application

73572	1" extended for 5 speed BT rubber mount 1985-90 (40266-85)
73626	1" extended for FXST 1991-05
73573	.500" extended for Softail 1985-90
73560	.500" extended for Softail 1991-03
73625	.500" extended for FXR-FLT 1985-90



73571

## BT Sprocket Nut 1970-on

### PCP Application

73571	1" extended (40392-70)
73612	As above 1991-05 style (hole thru)
73609	1/2" extended (40392-70)
73624	As above 1991-06 style (hole thru)



43409



43409

## 1" Extended Compensating Sprocket Kits

Available in 24T and 25T versions for Softail models.

PCP	Teeth	Years
43409	25T	1994-05 Softail & Touring, FXR 1994, & Dyna 1994-05 (except EFI 99-01)
43410	24T	1991-93



## 3 Spoke Swept Rear Sprocket

Chrome rotor features swept design.

71028	48T XL 1986-92
-------	----------------

# Chain



## Diamond Primary Chains

Endless link diamond chain for primary drive replacement on Big Twins, FLT and XL. Chain type links.

PCP	Size	Fitment
2657	428x2x82	BT 1936-06 (not touring models)
59498	428x2x96	BT 2007-on Softail/Dyna (40036-06)
59499	428x2x86	BT 2007-on Touring (40037-07)
59480	428x2x80	Special length
2658	428x2x76	FLT-FXR 1979-06
59481	428x2x74	1994-06 FLT special
2656	35x3x94	XL 1957-03 (for 34T)
2669	35x3x96	XL 2004-on (for 38T)

## Standard

Diamond 530 standard is the mainstay of the motorcycle chain. It has been continuously upgraded by raw material selection, improved heat treating methods and innovative manufacturing and production techniques to keep it in step with the demands of today's motorcycles.

PCP	Size	# of Links
2642	50STD	100
2643	50STD	102
2644	50STD	104
2645	50STD	106
4641	50STD	108
2646	50STD	110
4642	50STD	112
4643	50STD	120
2647	Master Links	5 Packs

## XDL Self Lube

530 XDL eliminates the possibility of hit and miss lubrication, as it has a constant and consistent lubrication in the pin bushing (wear) area. This chain combines the high strength and capacity of Diamond's proven performance with the advantages of fewer adjustment and less maintenance.

PCP	Size	# of Links
2637	50XDL	102
2638	50XDL	104
2639	50XDL	106
4546	50XDL	108
2640	50XDL	110
4547	50XDL	112
4548	50XDL	120
2641	Master Links	Each



## Compensator for FXST 1985-90

PCP	Item
1 11850	Spacer .010 (35850-84) (5 pk)
1 11851	Spacer .020 (35851-84) (5 pk)
1 11852	Spacer .030 (35852-84) (5 pk)
1 11810	Spacer .060 (24032-70)
1 11811	Spacer .090 (24033-70)
1 11812	Spacer .120 (24034-70)
1 11813	Spacer .150 (24035-70)
1 11814	Spacer .180 (24036-70)
1 11815	Spacer .210 (24037-70)
2 29076	24T Gear (40275-83A)
3 29077	Slider Cam 1985-05 (40299-83A)
29098	T/L, as above
4 29072	Shaft Extension (40375-70)
5 29078	Retainer w/Springs (40384-83A)
6 12569	Nut (40392-70)
** 29079	Complete kit w/24T gear (less spacers)

## Chrome Chain

For show and decorative use. 120 links by 530.

21811

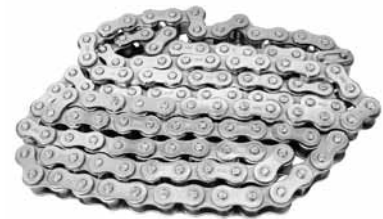

## Diamond Spare Parts Kit

Includes: 2 master links, 1 link and 1 offset link for all 530 heavy-duty chain.

4644 Spare parts kit



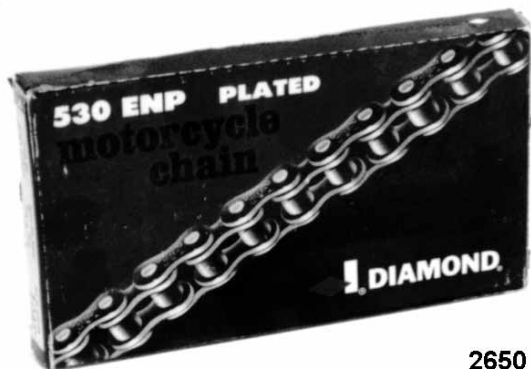

2650



4801

## Nickel Plated

Diamond chains are also available nickel plated, which offers rust-proof protection along with a brilliant chrome-like finish. Each part of these nickel plated chains is individually plated before assembly to insure maximum coverage.

PCP	Size	# of Links
2648	50ENP	100
2649	50ENP	102
2650	50ENP	104
2651	50ENP	106
4645	50ENP	108
2652	50ENP	110
4646	50ENP	112
4647	50ENP	120
2653	Master Links	Each

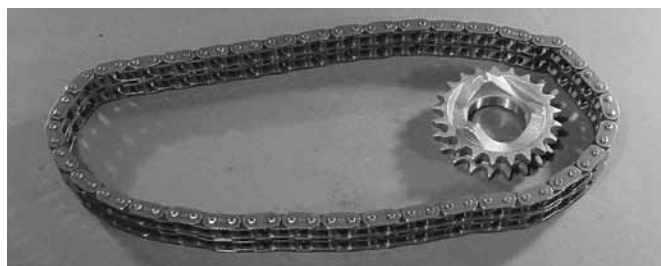

## Sifton Primary Gearing Kit

Use to increase acceleration by allowing the engine to turn higher RPM's. Changes primary ratio from stock 1.44:1 to 1.71:1. Kit includes new sprocket and Diamond primary chain.

PCP	Application
59470	1994-06 FXST, Dyna
59471	1994-06 FLT

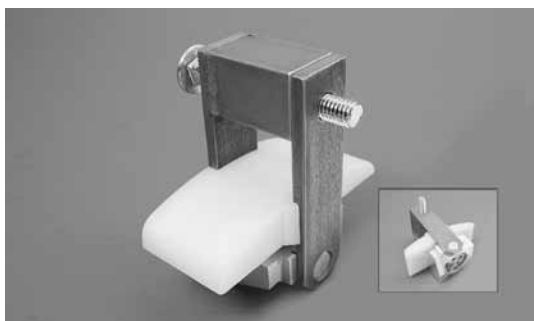

## Sifton BT Hydraulic Primary Chain Tensioner

Features a hydraulic valve which controls the motion of the submerged piston which constantly keeps the chain in tension for 1965-on BT.

59964

## XLO Diamond O Ring Chain

The features contained within the linkplates of Diamond 530XLO include a .214 Diamond pin which has been produced using a special alloy steel and case hardened for optimum strength and toughness, heavy series inside and outside linkplates, special constructed extended solid brushings, true wall solid rollers, quad staked pin heading, a whopping 9300 lbs. average tensile strength.

PCP	# of Links
4800	102
4801	104
4802	106
4803	108
4804	110
4812	112
4813	120

## XLO Connecting Links

4788 Each

## Chain Breaker

Good for cutting 530 chain  
26039



## Tech Note

For custom clearance concerns, o-ring chain is .970 OAL on pins. STD-XDL-Plated are .800 OAL on pins.

SPROCKET APPLICATION GUIDE					
Engine	Model	Stock Rear Sprocket*	Stock Front Sprocket*	Stock Ratio	Stock Chain
900	XLH 1958-66	51	22	2.32	530-104
	XLCH '58-59	51	22	2.32	530-104
900 & 1000	XLH 1967-80	51	22	2.32	530-106
	XLCH '70-80	51	22	2.32	530-106
1200	FL, FLH '62-66	51	22	2.32	530-102
	'67-72	51	22	2.32	530-102
	'73-78	51	22	2.32	530-102
1200	FX 1967-72	51	22	2.32	530-102
	1973-78	51	23	2.22	530-102
	FXS '73-78	51	23	2.22	530-102

# Chain Related



43112



1190



3747

## Nylon Primary Chain Shoe Adjustor

Replaces OEM #39973-65 lining. Also No. 39976-65B tensioner shoe. Use on 1965-00 74", 80".

1190

## Tensioner Anchor Plate

Replaces plate 39998-65, and nut 39992-65A on FX-FL 1965-up, heat treated detents for positive hold.

3747

## Rear Chain Tensioner

Use of tensioner reduces chain vibration and frequency of adjustments. Tensioner features a durable urethane roller which revolves on sealed bearings mounted on chrome anchor plates, except for FXST models which have stainless brackets.

### PCP Description

- 43112 FL, FLHS, FXE, FXWG 1973-85
- 43113 XL, XLH 1957-on
- 43114 FXST 1984-85

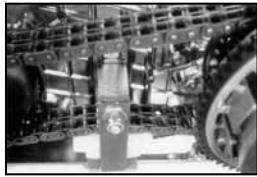

43403

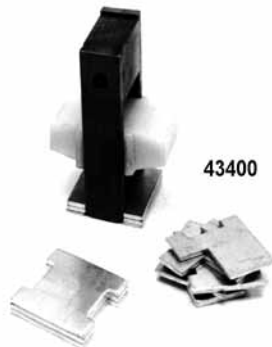

43400



## Primary Drive Kit 1994-06

Kit includes primary chain, compensating sprocket, chain tensioner and hardware.

62120 1994-06 Softail and Dyna (40035-00)

## York Self Adjusting Chain Tensioner Kit

Fits Big Twins 4 & 5-speed 1965-up replacing factory type detent adjuster shoe. Kit includes all hardware and detailed instructions for the complete conversion.

- 43400 BT 1965-00
- 43402 XL 4 speed 1977-90
- 43403 XL 5 speed 1991-on
- 43401 Replacement Shoe



29167



29165



29168



29166



43110

## Rhino Foot Primary Chain Adjusters

Adjuster comes complete with bracket, sprocket with needle bearing and hardware.

### PCP Description

- 43110 FXR series short case 5 speed and some Road Kings

## 34T Compensator Pieces BT 2007-on

### PCP Description (not for FXCWC)

- 29165 Compensator assembly (40296-06)
- 29166 Shaft extension (40297-06)
- 29167 34T Compensating sprocket (40320-06)
- 29168 Sliding cam (40333-06)
- 29200 Kit, FXST 2007-on

# Chain Related

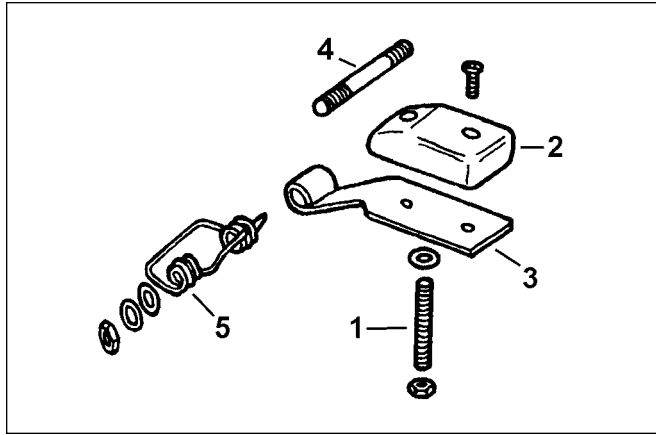

## Sportster "Primary Adjuster Shoe Kit"

Fits 1979-85, OEM on 1980-85, use to update 1977-79.

#	PCP	Item
	<b>60004</b>	Kit as above, 1986-90
1	<b>10902</b>	Adjuster stud 77-90 (each) (3250)
2	<b>3276</b>	Pad 1980-90 (39966-80)
3	<b>60002</b>	Carrier 1977-90 (39973-86)
4	<b>10858</b>	Stud 1977-85 (40018-77)
	<b>10859</b>	Stud 1986-90 (5 pk) (40018-86)
5	<b>13197</b>	Spring 1977-85 (each) (40019-80A)
	<b>13198</b>	Spring 1986-90 (each) (40019-86A)

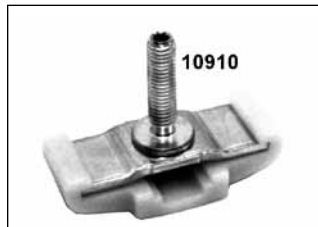
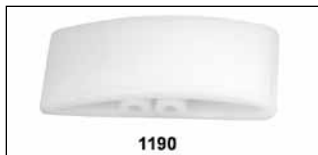

## Nylon Primary Chain Shoe Adjustor

PCP	Description
<b>1190</b>	74&80 1965-00 (39976-65B)
<b>3276</b>	XLH-XLCH 1980-90 (39966-80)
<b>10910</b>	XL 1991-01 Pad and adjuster (39975-90A)
<b>10916</b>	XL 2002-08 Pad and adjuster (40039-02C)



## Automatic Primary Chain Tension Adjuster

When installed it is no longer necessary to manually adjust the primary chain tension during regular maintenance. Stock on 2006-on Dyna, 2007-on Touring and Softail models and will fit 1985-on Evolution 1340 and Twin Cam models. Model specific primary gaskets and seals must be purchased separately.

<b>29029</b>	T/L (40063-05A)
<b>21740</b>	Preston as above

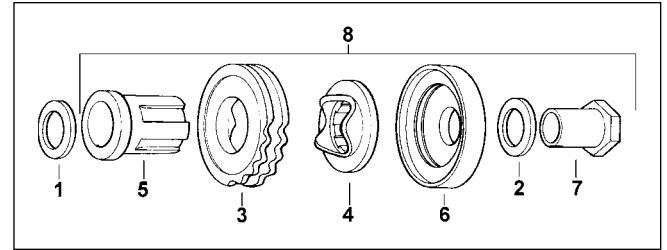

## Compensator

Fits FXST/Dyna 1991-05 & FLT/FXR 1985-05.

	PCP	Item
1	<b>11850</b>	Spacer .010 (5 pk) (35850-84)
	<b>11851</b>	Spacer .020 (5 pk) (35951-84)
	<b>11852</b>	Spacer .032 (5 pk) (35852-84)
	<b>11810</b>	Spacer .060 (ea) (24032-70)
	<b>11811</b>	Spacer .090 (ea) (24033-70)
	<b>11812</b>	Spacer .120 (ea) (24034-70)
	<b>11813</b>	Spacer .150 (ea) (24035-70)
	<b>11814</b>	Spacer .180 (ea) (24036-70)
	<b>11815</b>	Spacer .210 (ea) (24037-70)
	<b>11853</b>	Assortment of .060 to .210
2	<b>18001</b>	Spacer .220 (ea) (29960-91)
3	<b>29080</b>	24T Gear FLT 85-90 FXST 91-93 (40269-85A)
	<b>29093</b>	25T Gear 1994-05 (40308-94)
4	<b>29077</b>	Slider cam 1985-05 (40299-83A)
	<b>29098</b>	T/L, as above
5	<b>29081</b>	Shaft extension 1985-05 (40266-85)
	<b>29040</b>	T/L as above
6	<b>29082</b>	Retainer w/springs FXST/DYNA 91-05 (40384-91)
	<b>29099</b>	T/L, as above (also FL 1991-05)
	<b>43408</b>	as above for touring models 85-90 (40267-85)
7	<b>12612</b>	Nut straight through 1991-06 (40392-91)
8	<b>29083</b>	24T Kit (less spacers) 1991-93 FXST
	<b>29094</b>	25T kit (less spacers) 1994-05 FXST
	<b>29102</b>	24T kit (less spacers) FLT/FXR '85-90
	<b>29200</b>	24T kit FXST 2007-on



## BT Chain Tensioner Parts

PCP	Application
<b>24052</b>	Complete kit 1985-00
<b>24089</b>	Complete kit 2001-on
<b>24034</b>	Hardware kit 1965-99
<b>1190</b>	Nylon pad 1965-2000 (39976-65B)
<b>46036</b>	Nylon pad 2001-06 (39976-01)
<b>13731</b>	Lock (10 pack) (39996-65)
<b>27113</b>	Shoe mount bracket 1965-2000 (39990-65)
<b>46037</b>	Shoe mount bracket 2001-06 (39990-01)
<b>17502</b>	Plate (39993-65)
<b>3747</b>	Nut and anchor plate (39992-65A, 39998-65)

# Chain Guards



## Chrome Universal Rigid Chain Guard

For custom applications requiring a longer 25" guard.

**82019** Left side

**3176** Right side, XL hardtail guard



## Chrome Iso Mount Swing Arm Chain Guard

Use on all FLH-FXE-FXR models 1958-on Chain Drive models. Includes rubber bushing & rear bracket.

**PCP Application**

**451** FX-FL-FXE 1958-85, FXWG 1980-84 (60302-73T)

**24084** Mount kit

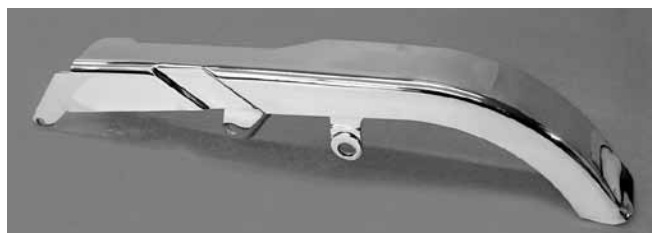

## 65T Chrome Rear Belt Guard FXST 1990-99

**85027** 60571-98

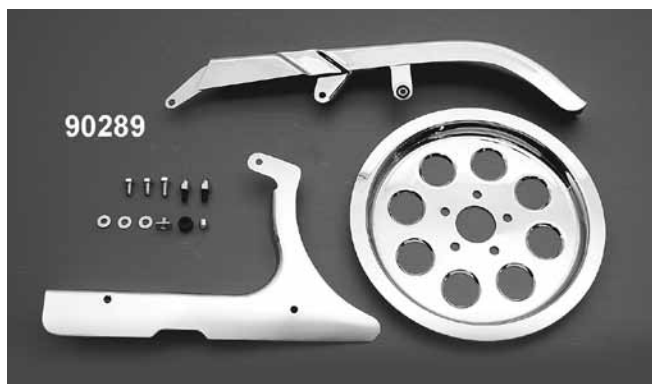

## Chrome Belt Guard Kits

Include pulley cover with upper and lower belt guard for FXST models.

PCP	Pulley	Year
<b>90289</b>	70T	1986-99
<b>90290</b>	61T	1990-99
<b>90291</b>	70T	2000-05
<b>90292</b>	70T	2006-on



## Chrome Dress Up Kits for FXD Models

Kits include upper and lower belt guard with a chrome pulley cover.

PCP	Pulley	Year
<b>90293</b>	70T	1991-99
<b>90294</b>	61T	1991-99
<b>90295</b>	70T	2000-05
<b>90296</b>		2007-on



## Chrome Shorty Upper Belt Guard

For FXD-FXDWG models.

**85033**

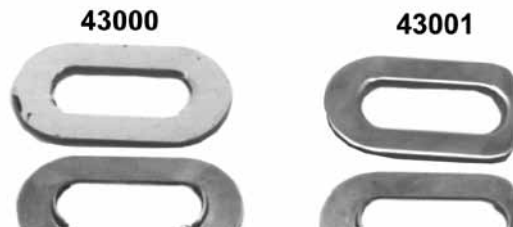

## Axle Plates

Made of polished stainless steel to protect axle area. (Pairs)

**PCP Models**

**43000** FXST-FLST 1984-99

**43001** FXR-FXRS 1982-on

**769\*** XL 1979-on

\* Requires drilling and tapping at axle area (drill and tap not included), but includes screws.



## Softail Chrome Rear Axle Adjusters

PCP	Application
<b>8934</b>	1986-92 (47579-86)
<b>9515</b>	1993-99 (47579-93)
<b>72023</b>	2000-on (47579-00)

# Belt/Chain Guards

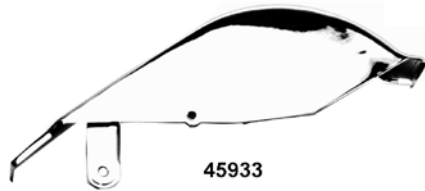

## “Ness Style” Belt Guards for FXST 1986-92

Add a touch of class with our new chromed, ribbed and slotted steel belt guards. Fit belt drives on Softails 1986-92 with 70T pulley.

**45933**

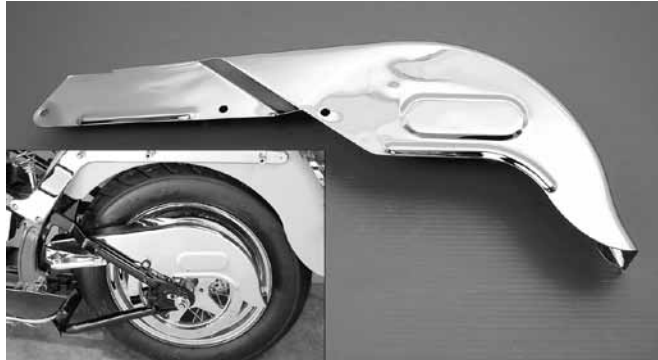

## FL Style Belt Guard for Softail®

Designed after the FL rear chain guard as OEM on 1963-84. This guard will fit all belt drive Softail® models. Provides a nostalgic look with better coverage in wet weather.

**45600** Fits all belt drive FXST 1986-on with 70T pulley.



## Chrome Lower Belt Guards

1985-on belt drive FXR & FXST, FLST. Note pulley tooth size.

PCP	Model
<b>6344</b>	70T FXR, FLHT, FLHS and Road king 1985-92 (60397-85)
<b>85011</b>	61T FXST-FLST 1993 (60394-90)
<b>45169</b>	65T FXST-FLST 1989-99 (60394-95)
<b>6610</b>	70T FXST-FLST 1986-92 and 1994 (60366-89A, 60362-86A)
<b>6823</b>	Louvered, as above
<b>45419</b>	70T FXST-FLST 2000-05 (60316-00)
<b>21816</b>	70T FXST/B/S 2006 (60317-06) (for 1" belt)
<b>21817</b>	70T FXST/B/C, FLSTF 2007-on (60655-07) (20mm)
<b>21818</b>	70T FXSTD, FLSTC/N/SC 2007-on (60654-07) (for 1" belt)
<b>45418</b>	70T FXR 1987-93, Touring 1987-96 (60478-93T)
<b>85007</b>	70/65T FXD 1991-05 (60475-92)
<b>85008</b>	61T FXD 1991-05 (60474-92)
<b>21822</b>	FXD 2006 (60489-06)
<b>45171</b>	XL 2004-on

Note: **6344** is designed to match **6816** upper belt guard.

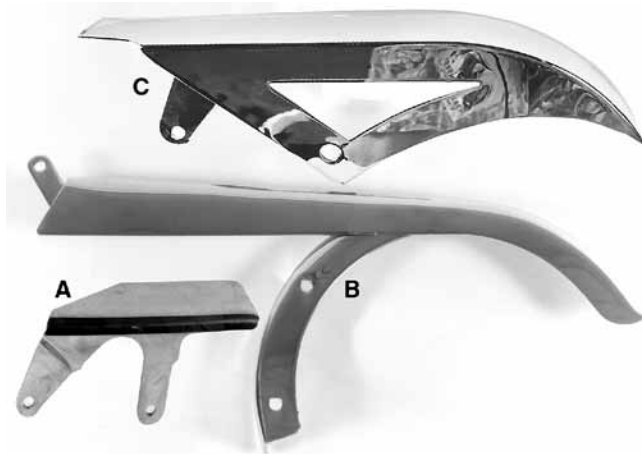

## FXST Chrome Guards

PCP	Application
<b>44113</b>	(A) Short belt guard 1986-99 FXST and FLST
<b>85020</b>	(B) Chain guard 1984-85 models with rear chain
<b>45282</b>	(C) Short belt guard 1986-99 FXST, FLST



## Chrome Rear Belt Guards

PCP	Fits
<b>6348</b>	1980-86 FXB-FXSB, 1984-86 FXWG (60388-82)
<b>6347</b>	1985-86 FXR-FXRS, 1987-92 FXRT (91774-85A)
<b>6816</b>	1987-94 FXR/S/LR (not convertible) (91739-87A)
<b>6814</b>	1986-99 FXST 70T (60533-86)
<b>85019</b>	1990-99 FXST 65T (60537-89)
<b>85026</b>	2000-05 FXST, 2000-06 FLST 70T (60533-00)
<b>85034</b>	2006-on FXST-FLST (60576-06)
<b>85013</b>	1992-99 FXD/L/X/WG (60293-90A)
<b>85014</b>	2000-05 Dyna models (60293-00)
<b>85032</b>	2006 Dyna models (60303-06)
<b>85027</b>	1990-99 65T FXST-FLST (60571-98)

# Belt Guards

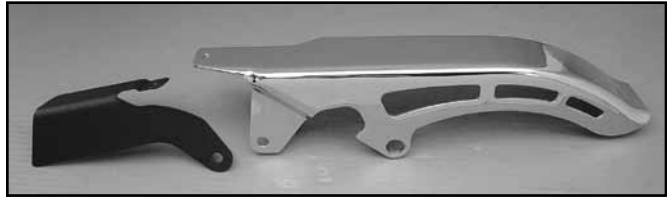
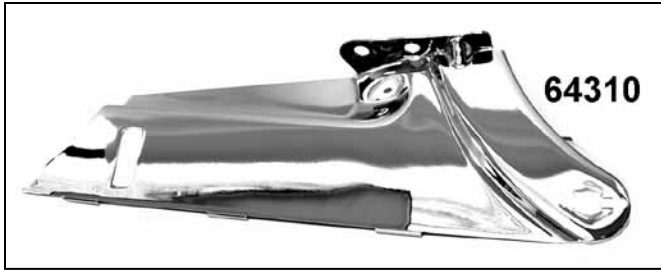
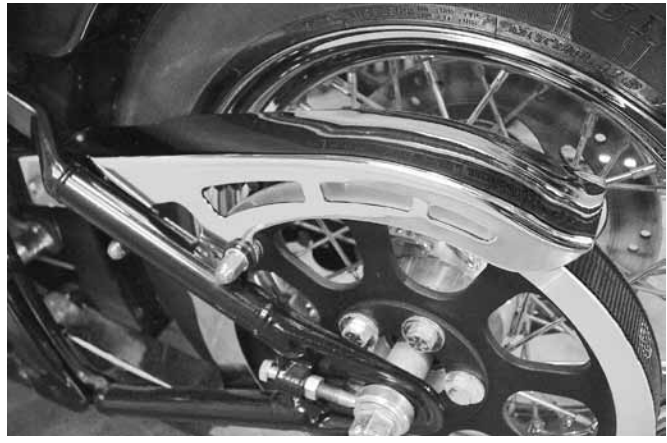
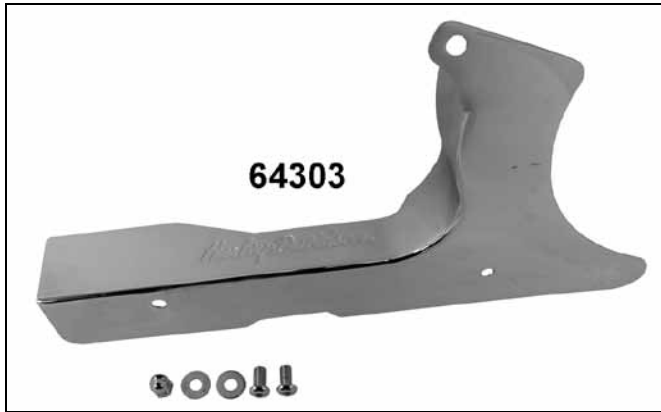

## Chrome Lower Belt Guard

Includes mounting hardware to replace black guard.

PCP	Application
64320	2007 FXSTD, FLSTC, FLSTN and FLSTSC models with 1" belt (60654-07)
64321	2007 FXST/B/C and FLSTF models with 20mm belt (60655-07) (Stock on 2007-08 FXSTSSE/2)
64319	2006 FXST/B/S (60317-06)
64318	2000-06 most Softail models except 2006 FXST/B/S (60316-00A)
64303	1995-99 FXST models with a 65T rear sprocket (60389-97A)
64310	70T Touring models 1997-08 (60491-02A)

## Shorty Chrome Upper Belt Guard

For FXST models. Includes mounting hardware.

PCP	Application	Belt
85029	1986-06 FX, FLST (60610-02)	1.25", 1.5"
85031	2007-on FLST	1"



## Chrome Lower Belt Guard

For FXD 1991-05

PCP	Teeth
85007	65T or 70T 1991-05 (60475-92A)
85008	61T (60474-92)



## FXST Upper & Lower Belt Guard Mount Kit

16579	Acorn kit 1986-99
16592	Acorn kit 2000-on
24160	Allen style mount kit 2000-on

# Chain Guard



45170



## Chrome Lower belt Guard 1991-on

**45170** XL 1991-03 (60480-94T)

**45171** XL 2004-on (91746-03)



## Chrome Adjuster Block Set

Fits 1991-on FXD models.

**43109**

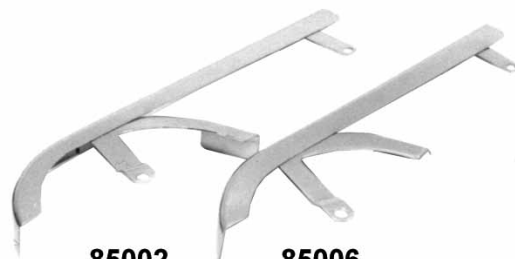

**85002**

**85006**

## Chrome Chain Guards for Sportster

With splatter apron.

**PCP** **Years**

**85002** L1987-92 Hugger 883, 1988-90 1200 Deluxe (60405-91 & 60405-87)

**85006** 1986-90 belt models (60381-91)



**85015**



**85017**

## Chrome Sportster Upper Belt Guards 1991-on

These easy to clean and install guards replace the original black version on XL models.

**PCP** **Application**

**85017** T/L 2004 XL (60402-04)

**85030** Preston's 2004 XL (60402-04)

**85016** 2000-03 XL (60481-00)

**85015** 1991-99 XL (60404-91 & 60381-91)

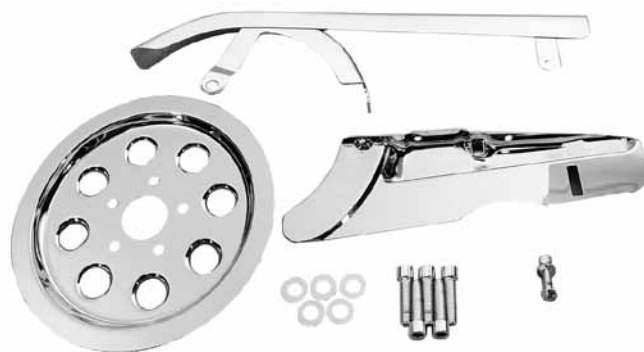

## XL Chrome Guard/Rear Pulley Dress Up Kit

Includes upper and lower belt guards and a 61T rear pulley cover with hardware for 5 speed belt drive models.

**45817** 1991-99

**45818** 2000-03

**45843** 2004-on

# Chain Adjusters



## Custom Axle Adjusters (Pairs)

- 43100** FXR models 1984-91  
**43101** Heavy-duty axle adjuster blocks prevent swingarm body collapse due to overtightening. Fits 4-speeds 73-86, FLT 80-83, FXR 82-\*, FXST 84-85 & XL 79-\*. (41570-77)

## OEM Style Axle Adjusters (Pairs)

- 43102** FLT, FLHT 1984-96. (41573-84, 41112-79, 7725)  
**3547** FXR 82-up and FLT 80-83 (41570-77, 41112-79, and 7725)  
**43115** FLT 1997-on (41573-97, 41112-79)  
**43116** XL 1997-on (41573-97, 47554-73A)



## Complete Rear Wheel Adjuster

Complete kit contains adjusters; chrome plated end plates, hex nuts, and custom chrome plated tapered lock nuts.

- 1778** BT 1973-up.  
 Chrome plated end covers and nuts replace the original equipment.  
**1802** FL-FX 1973-87, XL 1979-87, FXR 1981-87.

## Chrome Rear Wheel Adjusters

- | PCP          | Application                                  |
|--------------|--|
| <b>2504</b>  | FL-FX 1973-84,<br>XL 1979-92,<br>FXR 1981-87 |
| <b>72407</b> | FLT 1985-96                                  |



## Chrome Swing Arm End Plates & Custom Wheel Adjuster Hardware

- Fits all Dyna models 1991-on. Replaces 41113-90.  
**72000** End plates & adjuster hardware  
**72001** End plates only  
**9987** Adjuster hardware only  
**72090** End plates only FLT 1979-on, FXR 1981-94

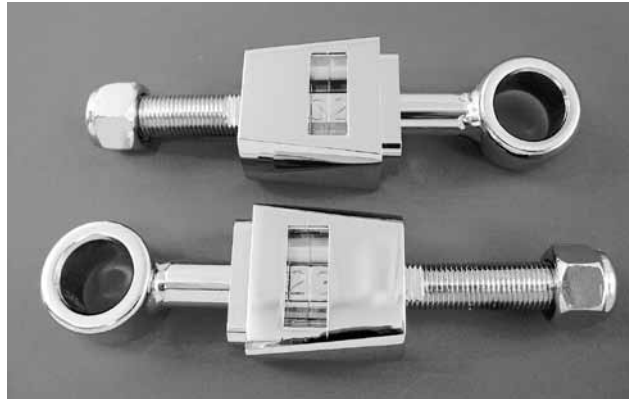

## Calibrated Rear Wheel Adjusters

Adjusters have chrome pyramid blocks with sight indicator to view calibrated adjuster bolt. Bolt is a heavy duty 1/2" rod with micrometer markings. Complete with chrome bolt and stainless steel nut.

- 43108** FX-FLH 73-85, XL 79-\*, FXST 84-86



## Pyramid Adjuster Blocks

Chrome, die cast for positive adjustment. Includes nuts. For BT 4 Spd. 1973-86 and XL 1979-96.

- 5585** With pull adjusters as pictured  
**5586** Chrome outer parts only (use your stock adjusters)

## Chrome Axle Adjuster

Kit includes adjusters, nuts and spacers. (47577-86, 47579-86 and 7783)

- 43103** Fits Softails 87-92



## Chrome Pyramid Axle Adjuster

- | PCP          | Application                   |
|--------------|-------------------------------|
| <b>27372</b> | XL 1997-03                    |
| <b>5586</b>  | XL 1979-96 (41532-89T) (pair) |
| <b>43118</b> | FLT Touring 1997-01           |